

HP Archive

This vintage Hewlett Packard document was
preserved and distributed by

[www. hparchive.com](http://www.hparchive.com)

Please visit us on the web !

Scanned by on-line curator: Tony Gerbic

**** For FREE Distribution Only *****

hp 130B



HEWLETT-PACKARD COMPANY / OPERATING AND SERVICE MANUAL

130B
OSCILLOSCOPE

hp 130B

OPERATING AND SERVICING MANUAL



MODEL 130B/BR OSCILLOSCOPE

SERIALS PREFIXED: 946 -



Copyright HEWLETT-PACKARD COMPANY 1959
275 PAGE MILL ROAD, PALO ALTO, CALIFORNIA, U. S. A.

130B002/11-59

SPECIFICATIONS

SWEEP

Sweep Range:	0.2 μ sec/cm to at least 12.5 sec/cm. 21 calibrated sweeps, accurate within $\pm 5\%$, in a 1-2-5-10 sequence, 1 μ sec/cm to 5 sec/cm. Vernier permits continuous adjustment of sweep time between calibrated steps and extends slowest sweep time to at least 12.5 sec/cm.
Magnifier:	X5 Magnifier may be used on all ranges and expands fastest sweep to 0.2 μ sec/cm. Accuracy within 10%.
Synchronization:	Internally from line voltage or from signals causing 1/2 centimeter or more vertical deflection. Externally from 0.5 volts peak-to-peak or more.
Trigger Point:	Continuously adjustable from -30 to +30 volts on either positive or negative slope of external synchronizing signal, or from any point of the vertical signal presented on the screen.
Preset Triggering:	Switch position on sweep mode control selects optimum setting for automatic triggering.

INPUT AMPLIFIERS

	Vertical and horizontal amplifiers have same characteristics.
Sensitivity:	1 mv/cm to at least 125 v/cm. 15 calibrated ranges, accurate within $\pm 5\%$, in a 1-2-5-10 sequence, 1 mv/cm to 50 v/cm. Vernier permits continuous adjustment between ranges and decreases sensitivity of 50 v/cm range to at least 125 volts/cm. Input voltage rating 600 volts dc or rms.
Phase Shift:	Within $\pm 1^\circ$ relative phase shift at frequencies up to 50 kc between vertical and horizontal amplifiers with verniers in cal.
Stability:	1 mv/hr after warmup.
Bandwidth:	DC Coupling: dc to 300 kc. AC Coupling: 2 cps to 300 kc. Specified bandwidth is independent of sensitivity setting.
Balanced Input:	On 1, 2, 5, 10, 20 and 50 mv/cm ranges. Cabinet Mount input impedance: 2 megohms shunted with approximately 25 μ f. Rack Mount input impedance: 2 megohms, approximately 125 μ f shunt capacity. Disconnecting the wires at the front panel which connect to the rear terminals reduces the input capacity to approximately 25 μ f.
Common Signal Rejection (Balanced input only):	Rejection at least 40 db. Common signal must not exceed 1.5 volts.

SPECIFICATIONS (CONT'D.)

Single Ended Input: Cabinet Mount input impedance: 1 megohm shunted with approximately 50 μf . Rack Mount input impedance: 1 megohm, approximately 200 μf shunt capacity. Disconnecting the wires at the front panel connecting to the rear terminals reduces the input capacity to approximately 50 μf .

Internal Calibrator: 300 millivolts peak-to-peak $\pm 2\%$, 300 cycles squarewave applied to vertical or horizontal amplifiers by CAL position of input attenuators.

GENERAL

Illuminated Graticule: Edge lighted graticule with controlled illumination, 10 cm x 10 cm, marked in centimeter squares with 2 mm subdivisions, on major horizontal and vertical axes. Effectively shielded from ambient light.

CRT Plates: Direct connection to deflection plates via terminals on rear. Sensitivity approximately 20 volts/cm.

Intensity Modulation: Terminals on rear; 20 volts positive signal blanks CRT at normal intensity.

Cathode Ray Tube: 5 AQP mono-accelerator flat face type with 3000 volt accelerating potential. Available with P1, P2, P7 or P11 screen.

Dimensions: Cabinet Mount: 9-3/4 in. wide, 15 in. high, 21-1/4 in. deep.
Rack Mount: 19 in. wide, 8-3/4 in. high, 22 in. deep, 19-3/4 in. deep behind panel.

Weight: Cabinet Mount: Net 41 lbs., shipping 54 lbs.
Rack Mount: Net 47 lbs, shipping 62 lbs.

Power Supply: 115/230 volts $\pm 10\%$, 50/1000 cycles, 160 watts.

Filter Supplied: Color of filter compatible with screen phosphor.
Green for P1 and P2, Amber for P7, Blue for P11.

Rack Mount: Has rear terminals in parallel with front panel connections.

Accessories Furnished: Supplied with Rack Mount. 130B-12P and Q Mounting Brackets (pr.)
Two 125-57 Plugs (mate with rear terminals).
Two 125-59 Clamps for 125-57 Plugs.

Accessories Available: AC-83A Viewing Hood; face-fitting molded rubber.
Additional Mounting Brackets. 130B-12P (left) and 130B-12Q (right)

CONTENTS

SECTION I	GENERAL DESCRIPTION	PAGE
1 - 1	General	I - 1
1 - 2	Damage in Transit	I - 1
1 - 3	Power Line Voltages	I - 1
1 - 4	Power Cord	I - 1
1 - 5	Installation of Rack Mount	I - 1
SECTION II	OPERATING INSTRUCTIONS	
2 - 1	Controls and Terminals	II - 1
2 - 2	Rear-Access Terminals	II - 1
2 - 3	Warm-Up Drift	II - 1
2 - 4	AC or DC Coupling	II - 2
2 - 5	Balanced Inputs	II - 2
2 - 6	Operating Procedures	II - 2
SECTION III	THEORY OF OPERATION	
3 - 1	General Content	III - 1
3 - 2	Over-All Operation	III - 1
3 - 3	Vertical Amplification Channel	III - 1
3 - 4	Horizontal Amplification Channel	III - 2
3 - 5	Sweep Generator	III - 2
3 - 6	Low Voltage Power Supply	III - 3
3 - 7	High Voltage Power Supply	III - 4
3 - 8	Calibrator	III - 4
SECTION IV	MAINTENANCE	
4 - 1	Introduction	IV - 1
4 - 2	Simple Check Procedure	IV - 1
4 - 3	Isolating Troubles to Major Sections	IV - 3
4 - 4	Removing the Cabinet	IV - 3
4 - 5	Connecting for 230 Volt Operation	IV - 3
4 - 6	Tube Replacement	IV - 4
4 - 7	Condensed Test and Adjustment Procedure	IV - 5
4 - 8	Adjustment Procedure	IV - 9
4 - 9	Turn On	IV - 9
4 - 10	Power Supplies	IV - 9
4 - 11	Replacing and Adjusting the CRT	IV - 11
4 - 12	Checking and Adjusting the Calibrator	IV - 13
4 - 13	Adjusting the Vertical Amplifier	IV - 13
4 - 14	Adjusting the Horizontal Amplifier	IV - 15
4 - 15	Phase Shift Adjust	IV - 15
4 - 16	Adjusting Preset	IV - 17
4 - 17	Adjusting the Sawtooth Generator and Sweep Amplifier	IV - 17
SECTION V	TABLE OF REPLACEABLE PARTS	
5 - 2	Table of Replaceable Parts	V - 2



CATHODE RAY TUBE WARRANTY

The cathode ray tube supplied in your Hewlett-Packard Oscilloscope and replacement cathode ray tubes purchased from , are guaranteed against electrical failure for one year from the date of sale by the Hewlett-Packard Company. Broken tubes or tubes with burned phosphor are not included in this guarantee.

Your local Hewlett-Packard representative maintains a stock of replacement tubes and will be glad to process your warranty claim for you. Please consult him.

Whenever a tube is returned for a warranty claim, the reverse side of this sheet must be filled out in full and returned with the tube. Follow shipping instructions carefully to insure safe arrival, since no credit can be allowed on broken tubes.

SHIPPING INSTRUCTIONS

- 1) Carefully wrap the tube in 1/4" thick cotton batting or other soft padding material.
- 2) Wrap the above in heavy kraft paper.
- 3) Pack in a rigid container which is at least 4 inches larger than the tube in each dimension.
- 4) Surround the tube with at least four inches of packed excelsior or similar shock absorbing material. Be certain that the packing is tight all around the tube.
- 5) Tubes returned from outside the continental United States should be packed in a wooden box.
- 6) Ship prepaid preferably by AIR FREIGHT or RAILWAY EXPRESS. We do not recommend parcel post or air parcel post shipment.

CRT WARRANTY CLAIM

FROM: _____ DATE: _____

NAME: _____

COMPANY: _____

ADDRESS: _____

Person to contact for further information:

NAME: _____

TITLE: _____

COMPANY: _____

ADDRESS: _____

To process your claim quickly please enter the information indicated below:

1) ϕ INSTRUMENT MODEL _____ SERIAL _____

2) TUBE TYPE _____ SERIAL _____

3) ORIGINAL TUBE _____ REPLACEMENT TUBE _____

4) YOUR PURCHASE ORDER NO. _____

5) DATE PURCHASED _____

6) PURCHASED FROM _____

7) COMPLAINT: (Please describe nature of trouble) _____

8) OPERATING CONDITIONS: (Please describe conditions prior to and at time of failure) _____

SIGNATURE _____

SECTION I

GENERAL DESCRIPTION

1-1 GENERAL

The Model 130B dc to 300 kc Oscilloscope is a general purpose oscilloscope. It can be used with either internal or external sweeps which can be either internally or externally synchronized and it can be obtained in either the cabinet or rack type mounting. Because of its high sensitivity and balanced input, the Model 130B may often be used directly with transducers, enabling you to see a direct presentation of phenomena desired without having to resort to preamplifiers.

Some of the special features of this oscilloscope are as follows:

A. LINEAR INTEGRATOR SWEEP GENERATOR

The accurate direct reading sweeps are obtained from a feedback type integrator which insures a high order linearity and stability. This type of sweep generator, is more reliable and independent of tube characteristics than other types of sweep generator.

B. X5 SWEEP EXPANSION

You speed observation and analysis of transients by expanding a two centimeter segment of the trace to 10 centimeters for easy viewing of detail. This X5 sweep expander, may be used on all sweep time settings and expands the fastest sweep time to .2 microsecond/cm.

C. CALIBRATED AMPLIFIERS

Voltage measurements of various waveforms are quickly made with the 130B, accurate within $\pm 5\%$. A built-in calibrator which is accurate within $\pm 2\%$ permits quick verification and standardization of the amplifier gain.

Phase shift measurements can be made accurately with this oscilloscope over a wide range of input frequencies.

1-2 DAMAGE IN TRANSIT

This instrument should be thoroughly inspected when it is received. If any damage is evident, refer to the "Claim for Damage in Shipment" paragraph on the Warranty sheet in this manual.

1-3 POWER LINE VOLTAGES

The Oscilloscope is shipped from the factory wired for 115 volts ac line operation, unless otherwise specified. However, the instrument may also be operated from a 230 volts ac line source if the proper conversion is made to the power transformer. This conversion is described in the Maintenance Section (Section IV).

1-4 POWER CORD

The three conductor power cable supplied with the instrument is terminated in a polarized three prong male connector recommended by the National Electrical Manufacturers' Association. The third contact is an offset round pin, added to a standard two-blade ac plug, which grounds the instrument chassis when used with the appropriate receptacle. An adapter should be used to connect the NEMA plug to a standard two contact output. When the adapter is used, the ground connection becomes a short lead from the adapter which should be connected to a suitable ground for the protection of operating personnel.

1-5 INSTALLATION OF RACK MOUNT

The Φ 130BR is designed so that it can be supported in a 19 inch rack by the front panel in the usual manner; or, the dust cover may be rigidly mounted in the rack with brackets as shown in Figure 1-1. In the latter case, the chassis is supported by the dust cover and may be slipped in

or out easily; the screws through the front panel merely holding the chassis in place. To rack mount the 130BR using the brackets:

1) Mount the bracket as shown in Figure 1-1 with screws through the outside holes of the brackets. The length of these screws may be chosen to space the front panel from the panel rails as desired. The brackets at the rear are not necessary in most installations but can be used if added support is required. These brackets are available from the Hewlett-Packard Company as an accessory item.

2) Remove the dust cover from the 130BR and mount it in the brackets with the 10-32 trusshead screws provided.

3) Slip the 130BR into the dust cover and fasten in place with screws through the front panel.

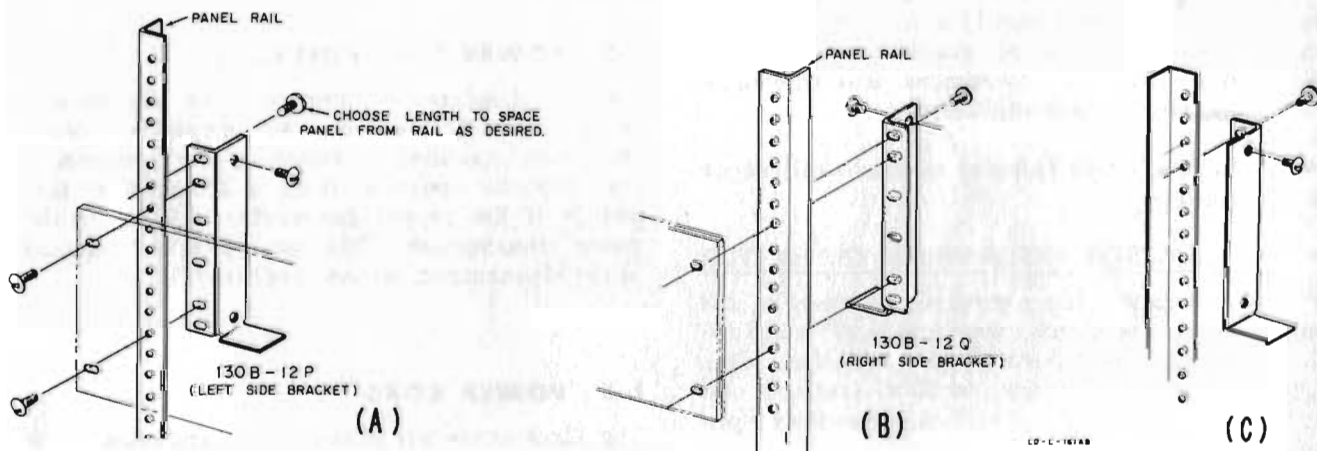

Figure 1-1. Model 130BR Installation

ADJUST FOR BEST TRACE RESOLUTION

ADJUST FOR STATIONARY POSITION WHEN **VERT. SENSITIVITY** IS SWITCHED. SEE FIGURE 2-3.

NOTE: IN THE CABINET MODEL, PLACEMENT OF CONTROLS IS DIFFERENT BUT FUNCTIONS ARE THE SAME.

ADJUST TRACE BRIGHTNESS

ADJUST FOR STATIONARY HORIZONTAL POSITION WHEN **HORIZ. SENSITIVITY** IS SWITCHED. (SEE FIGURE 2-4)

SET BASIC SWEEP TIME/CM $\pm 5\%$ WITH **VERNIER** SET TO **CAL.**

ADJUST SWEEP SPEED BETWEEN STEPS OF **SWEEP TIME/CM**

ADJUST VERTICAL POSITION

SET DESIRED VERTICAL SENSITIVITY ($\pm 5\%$) WITH **VERNIER** SET TO **CAL.** TO CHECK SENSITIVITY SET TO **CAL.**

ADJUST VERTICAL SENSITIVITY BETWEEN STEPS OF **VERT. SENSITIVITY**

SET TO **AC** TO REMOVE DC COMPONENT OF INPUT SIGNAL. SET TO **DC** TO PASS DC COMPONENT OF INPUT SIGNAL.

CONNECT SIGNAL TO VERTICAL INPUT TERMINALS. BALANCED INPUTS MAY BE USED ON 1 TO 50 MILLIVOLTS/CM RANGES.

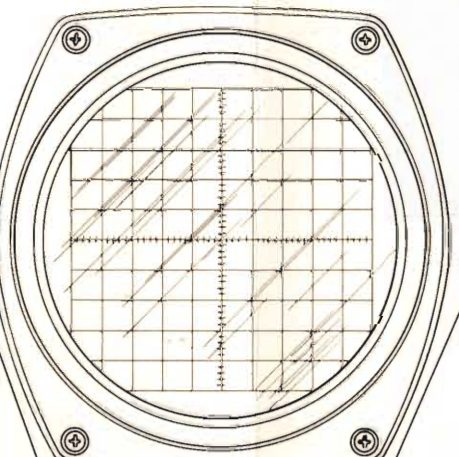

OSCILLOSCOPE MODEL 130B HEWLETT PACKARD PALO ALTO CALIFORNIA

FOCUS INTENSITY SCALE LIGHT POWER OFF

POWER SWITCH OFF TURN TO BRIGHTEN GRATICULE MARKINGS.

REMOVE SHORTING BAR WHEN CONNECTING A BALANCED INPUT SIGNAL.

CONNECT SIGNAL TO HORIZONTAL/SYNC INPUT TERMINALS. BALANCED AMPLIFIER INPUT SIGNALS MAY BE USED ON 1 TO 50 MILLIVOLTS/CM RANGES.

HORIZ DC BAL

HORIZ POS

VERNIER HORIZ SENSITIVITY

SWEEP MODE TRIGGER SYNC FREE RUN

ADJUST HORIZONTAL POSITION

ADJUST HORIZONTAL SENSITIVITY BETWEEN STEPS OF THE **HORIZ. SENSITIVITY** SELECTOR.

INPUT DC

INPUT AC

VERNIER SWEEP TIME/CM MILLISECONDS SECONDS

TRIGGER SLOPE TRIGGER LEVEL

ADJUST TO TRIGGER SWEEP FROM A PARTICULAR VOLTAGE (-30V TO +30V) LEVEL IF EXTERNAL SYNCHRONIZATION IS USED, OR FROM A PARTICULAR VERTICAL DEFLECTION LEVEL IF INTERNAL SYNCHRONIZATION IS USED.

ADJUST HORIZONTAL SENSITIVITY BETWEEN STEPS OF THE **HORIZ. SENSITIVITY** SELECTOR.

SET TO **X1** FOR BASIC INTERNAL SWEEP. SET TO **X5** TO EXPAND BASIC SWEEP. SET TO **CAL.** TO APPLY THE INTERNAL CALIBRATING SIGNAL TO HORIZONTAL AMPLIFIER. SELECT DESIRED HORIZONTAL SENSITIVITY ($\pm 5\%$), **VERNIER** IN **CAL.**

PRE-SET

EXT.

SET TO **LINE** TO SYNCHRONIZE SWEEP FROM LINE VOLTAGE. SET TO **INT** TO SYNCHRONIZE SWEEP FROM VERTICAL INPUT SIGNAL. SET TO **EXT** TO SYNCHRONIZE SWEEP FROM EXTERNAL SYNC SIGNAL.

TURN TO **PRE-SET** FOR MOST SYNCHRONIZING SIGNALS. TURNING FROM **PRE-SET** FIRST LOCKS OFF SWEEP AND THEN FREE-RUNS AS IT IS TURNED FURTHER.

SET TO **AC** TO REMOVE OR TO **DC** TO PASS THE DC COMPONENT OF THE HORIZONTAL OR SYNCHRONIZING SIGNAL.

LD-E-116/1178

SECTION II OPERATING INSTRUCTIONS

2-1 CONTROLS AND TERMINALS

Front panel operation controls are shown in Figure 2-1. This description of the operating controls enables you to operate the instrument if you have a basic knowledge of oscilloscope technique. Detailed operating procedures are given in the operating plates.

INTERNAL SWEEP CONTROLS

SWEEP TIME/CM -

This switch determines the speed at which the crt beam crosses the screen. HORIZ. SENSITIVITY switch must be in an INT. SWEEP position or internal sweeps are not generated. Associated with the SWEEP TIME/CM switch is a concentric VERNIER which provides continuous adjustment of sweep speed between steps. A X5 sweep magnifier operates on all ranges.

SYNC -

This three position switch lets the sweep be triggered either internally or externally. Internal triggering can be accomplished from a line frequency signal or from an applied vertical input signal of sufficient amplitude to produce a one-half centimeter deflection. External triggering can be produced by signals having amplitude greater than 0.5 volt, peak-to-peak.

SWEEP MODE -

As this control is rotated from the extreme clockwise position, the sweep generator will pass from an un-synchronized free-running (FREERUN) condition through a condition where only triggered operation is possible (TRIGGERED) to a position in which sweeps will not occur. At the extreme counterclockwise position the control switches into a PRESET position. This position provides optimum triggering bias for nearly all waveforms.

TRIGGER LEVEL -

This continuous control selects the level on the sync waveform where triggering is to occur. When the TRIGGER LEVEL control is set to zero, the trigger circuits are the most sensitive.

TRIGGER SLOPE -

This two-position switch, concentric with TRIGGER LEVEL, permits triggering to occur on either the positive or negative slope of internal, external or line voltage sync signals.

Horizontal or Sync INPUT -

A set of three binding posts used for receiving external sync voltages and external generated sweeping voltages. On the rack mount model only, a 3-conductor receptacle J102, mounted at the rear of the instrument, is connected in parallel with the binding posts.

2-2 REAR-ACCESS TERMINALS

-----DANGER - HIGH VOLTAGE-----

The following terminals are accessible through the rear access plate of the instrument cabinet: Horizontal and vertical deflection plates, and a terminal for crt intensity (Z-axis) modulation. See Figures 2-8 and 2-10.

2-3 WARM-UP DRIFT

When the oscilloscope is first turned on, drift in the trace will be quite noticeable, particularly at high sensitivities, the trace drift is fastest immediately following turn-on, becoming slower as the instrument warms up. Because of this drift, fine adjustment of amplifier balance should not be attempted until the instrument is thoroughly warm. For most purposes a 5 minute warm-up will be adequate.

2-4 AC OR DC COUPLING

AC coupling permits high gain to be employed without regard for the dc level involved. In the AC position the input signal (vertical or horizontal) is coupled to the amplifier through a capacitor which removes the dc component from the input. This coupling circuit has a low frequency cut-off at 2 cps. To avoid degrading input pulses or square waves below 200 cps it is advisable to use dc coupling. WHEN USING DC COUPLING THE AVERAGE VALUE OF THE DC DETERMINES THE POSITION OF THE SWEEP ON THE OSCILLOSCOPE. IF YOU ARE UNABLE TO FIND THE TRACE WITH THE VERTICAL POSITION CONTROL WHEN USING DC COUPLING, TRY AC COUPLING. When AC coupled the maximum dc that may be applied is 600 volts.

2-5 BALANCED INPUTS

The instrument will accept balanced input signals on the six most sensitive ranges. This arrangement is shown in Figure 2-7.

Driving the instrument from a balanced source can be very effective in removing the unwanted stray pickup that would otherwise obscure the desired information. To take advantage of the noise reduction that is possible with a balanced input, you must be sure that neither terminal of the source is connected to ground, and use double conductor shielded cable between the source and oscilloscope. The input cable shield must be connected to a suitable ground, either at the oscilloscope or some other point. With these precautions in the external input circuit, any stray signals (noise, hum, etc.) will be coupled equally to the two input terminals, and be cancelled by the differential amplifiers. Since the desired information is applied between the two input terminals, it will be amplified and displayed in the normal manner. Since the noise is a problem

mainly at low level, the fact that balanced input is available only on the most sensitive ranges is generally not a serious limitation.

The common-mode signal rejection will be at least 40 db (1/100 of the input signal). When using a balanced input certain limitations must be considered. The proper operating levels must be maintained on the input amplifier: The COMMON-MODE SIGNAL VOLTAGE MUST NOT EXCEED 1.5 VOLTS EITHER POSITIVE OR NEGATIVE, ON EITHER INPUT TERMINAL. Note that this is the sum of all voltages (dc plus peak ac).

NOTE

If balanced ac coupling is desired, it is necessary to connect a capacitor in the external signal path to the middle terminal, since a dc voltage on this terminal only unbalances the amplifier. This arrangement is shown in Figure 2-7.

2-6 OPERATING PROCEDURES

Basic operating procedures are described in the following illustrations. Positions of controls are different on the cabinet model but their functions are identical to those of the rack model.

Figure	Description
2-2	VERTICAL BALANCE ADJUSTMENT
2-3	HORIZONTAL BALANCE ADJUSTMENT
2-4	INTERNAL SWEEP-INTERNAL SYNCHRONIZATION
2-5	INTERNAL SWEEP-EXTERNAL SYNCHRONIZATION
2-6	EXTERNAL HORIZONTAL INPUT
2-7	AC COUPLING BALANCED INPUT
2-8	CONNECTION TO CRT DEFLECTION PLATES
2-9	EXTERNAL INTENSITY MODULATION
2-10	ALIGNING SCOPE TRACE WITH GRATICULE

In Figure 2-2, delete step 12. A separate adjustment (Bal. Adj. control on the etched board) is provided to balance the VERNIER. age 3

VERTICAL BALANCE ADJUSTMENT

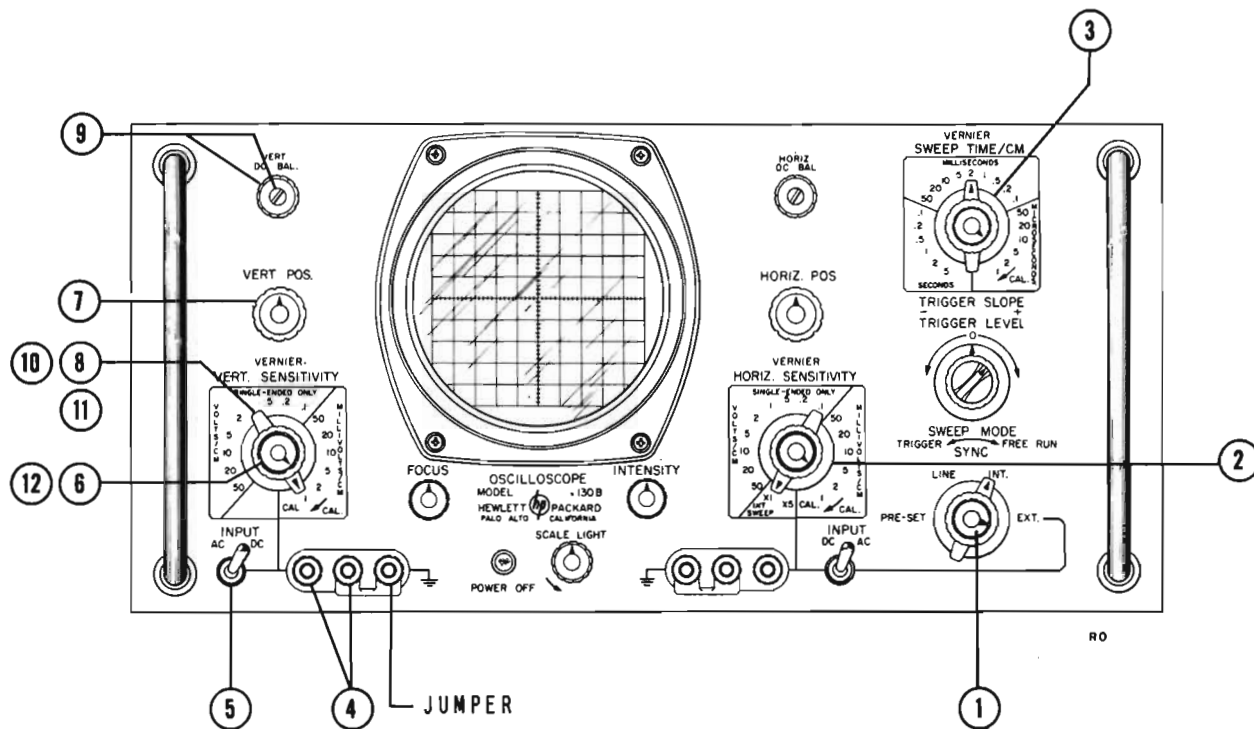

After Warm-Up:

1. Turn SWEEP MODE control to FREE RUN.
 2. Set HORIZ. SENSITIVITY switch to INT. SWEEP X1.
 3. Set SWEEP TIME/CM switch so that a convenient base line is formed. (Any sweep time faster than 50 MILLISECONDS/CM is satisfactory.)
 4. Short vertical input terminals together.
 5. Set AC-DC switch to DC.
 6. Turn VERNIER to CAL.
 7. Center trace with VERT. POS. control.
 8. Set VERT. SENSITIVITY to 50 MILLIVOLTS/CM.
 9. Center trace with coarse (screwdriver) VERT. DC BAL. control or with fine (knob) control if unbalance is slight.
 10. Set VERT. SENSITIVITY to 5 MILLIVOLTS/CM, repeat step 9.
 11. Set VERT. SENSITIVITY to 1 MILLIVOLT/CM, repeat step 9.
 12. Turn VERNIER fully CCW, repeat step 9.
- Repeat steps 6 through 12 until the trace does not move as the VERNIER control is rotated.

Figure 2-2

In Figure 2-3, delete step 9. A separate adjustment (Bal. Adj. control on the etched board) is provided to balance the VERNIER. 130B

HORIZONTAL BALANCE ADJUSTMENT

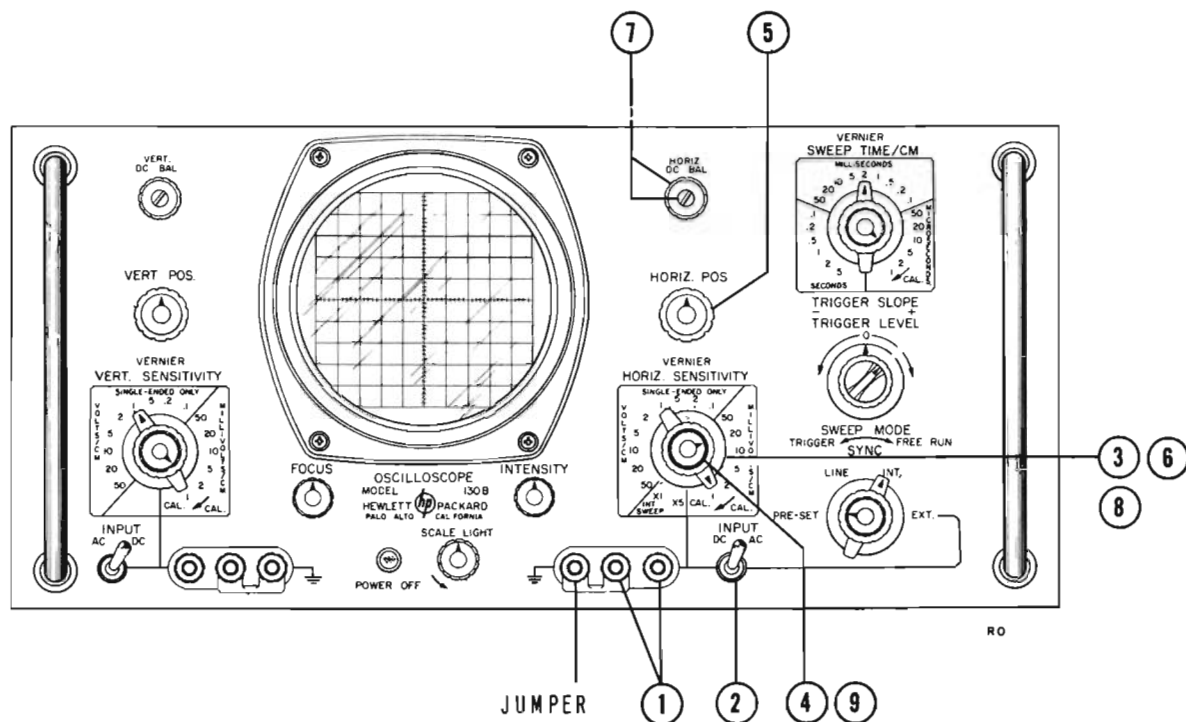

After Warm-Up:

1. Short together the horizontal input terminals.
2. Set AC-DC switch to DC.
3. Set HORIZ. SENSITIVITY to 50 MILLI-VOLTS/CM.
4. Turn VERNIER to CAL.
5. Center spot with HORIZ. POS. control, if necessary, adjust vertical position.
6. Set HORIZ. SENSITIVITY to 5 MILLI-VOLTS/CM.
7. Return the spot to center with coarse (screw-driver) HORIZ. DC BAL. control or with the fine (knob) control if the unbalance is slight.
8. Set HORIZ. SENSITIVITY to 1 MILLIVOLT/CM, repeat step 7.
9. Turn VERNIER fully CCW, repeat step 7.

Repeat steps 4 through 9 until the spot does not move as the VERNIER control is rotated.

Figure 2-3

INTERNAL SWEEP - INTERNAL SYNCHRONIZATION

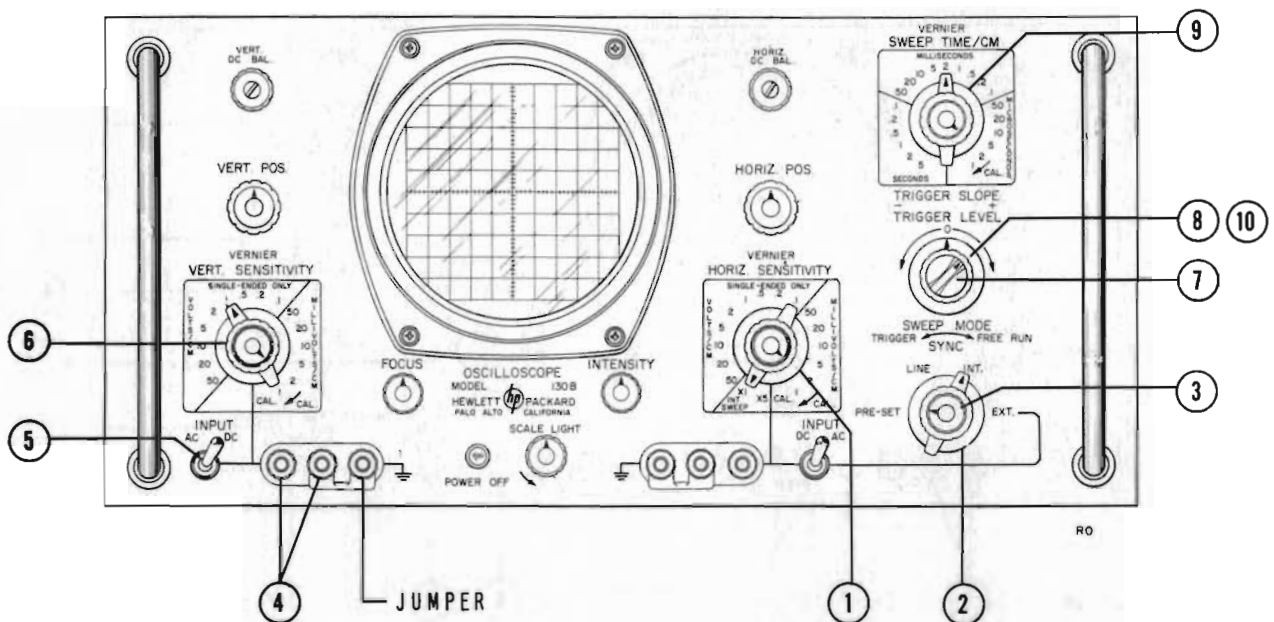

1. Set HORIZ. SENSITIVITY switch to INT. SWEEP X1 (or to X5 for magnified sweeps)
2. Set SYNC switch to INT.
3. Set SWEEP MODE to PRESET.
4. Connect vertical input signal into vertical input terminals.
5. Set AC-DC switch for type coupling desired.
6. Adjust VERT. SENSITIVITY for desired sensitivity.
7. Set TRIGGER SLOPE switch for triggering on positive or negative slope of input signal, as desired.
8. Set TRIGGER LEVEL control to 0.
9. Select desired sweep speed with SWEEP TIME/CM switch.
10. Adjust TRIGGER LEVEL to start trace at desired level. In some cases, it may be necessary to switch SWEEP MODE from PRESET to an individual adjustment for the particular trace being viewed.

Figure 2-4

INTERNAL SWEEP - EXTERNAL SYNCHRONIZATION

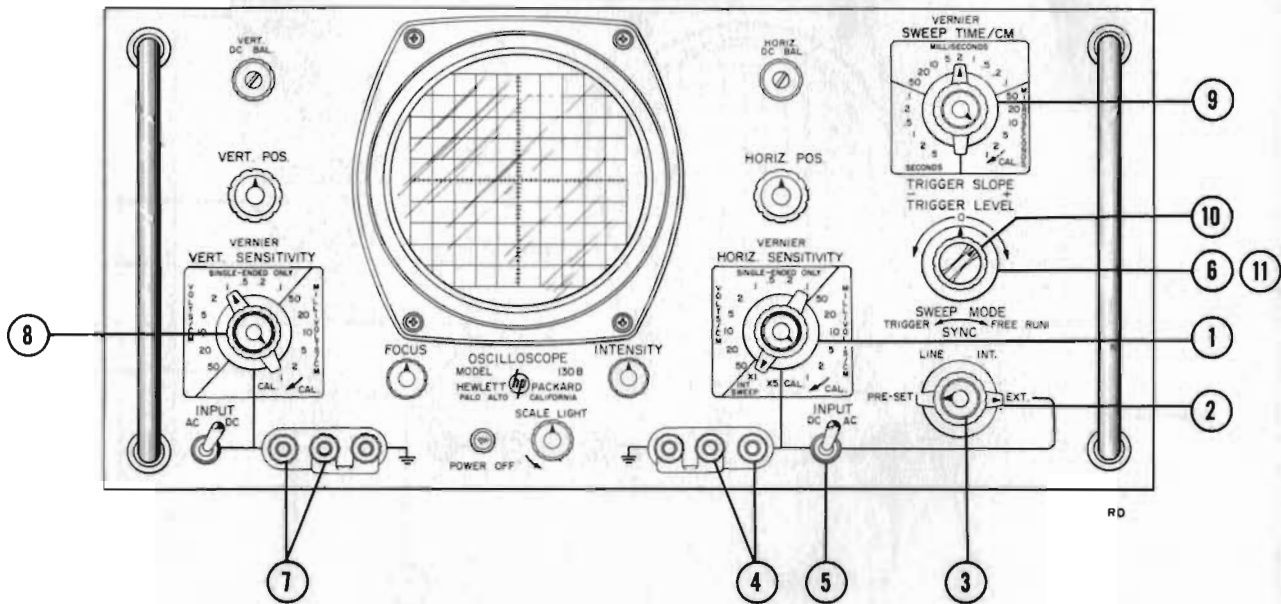

1. Set HORIZ. SENSITIVITY switch to INT. SWEEP X1 (or to X5 for magnified sweeps).
2. Set SYNC switch to EXT.
3. Set SWEEP MODE to PRESET.
4. Feed synchronizing signal (0.5 volts p-p or more) to the horizontal input terminals.
5. Set AC-DC switch for type coupling desired.
6. Set TRIGGER LEVEL to 0.
7. Feed vertical input signal into vertical input terminals.
8. Adjust VERT. SENSITIVITY for desired sensitivity.
9. Select desired sweep speed with SWEEP TIME/CM switch.
10. Set TRIGGER SLOPE for triggering on positive or negative slope, as desired.
11. Adjust TRIGGER LEVEL to start trace at desired level. In some cases, it may be found necessary to switch SWEEP MODE from PRESET to an individual adjustment for the particular trace being viewed.

Figure 2-5

EXTERNAL HORIZONTAL INPUT

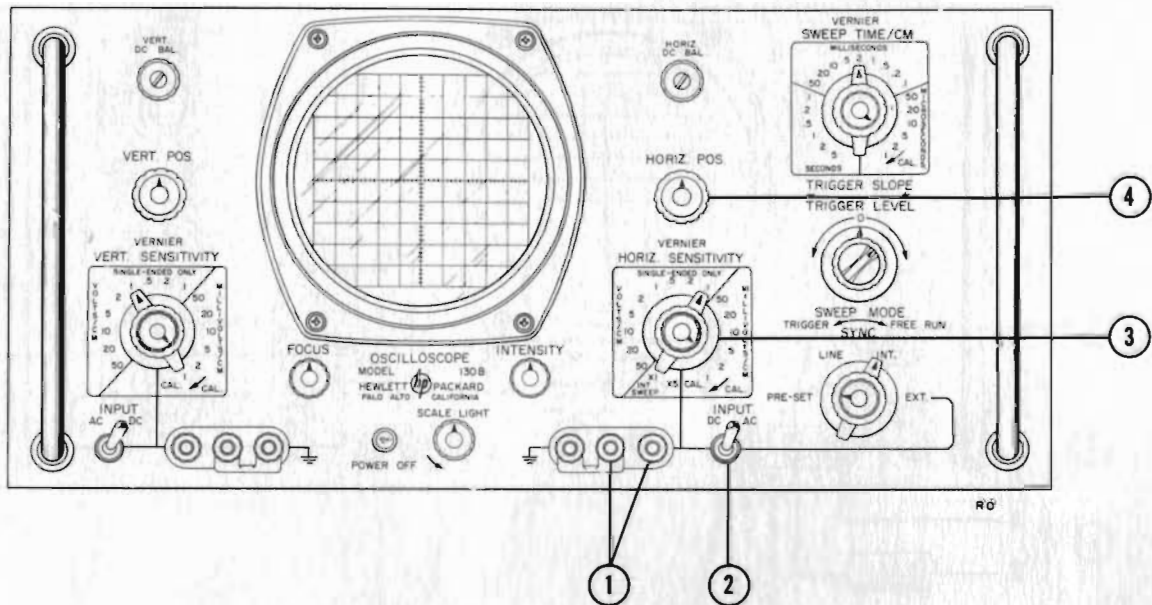

1. Feed horizontal signal to horizontal input terminals.
2. Set AC-DC switch for type of input coupling desired.
3. Set HORIZ. SENSITIVITY switch for desired sensitivity.

4. Adjust horizontal position of pattern with HORIZ. POS. control.

This type of input will be found useful for viewing Lissajous patterns, etc.

Figure 2-6

AC COUPLING BALANCED INPUT

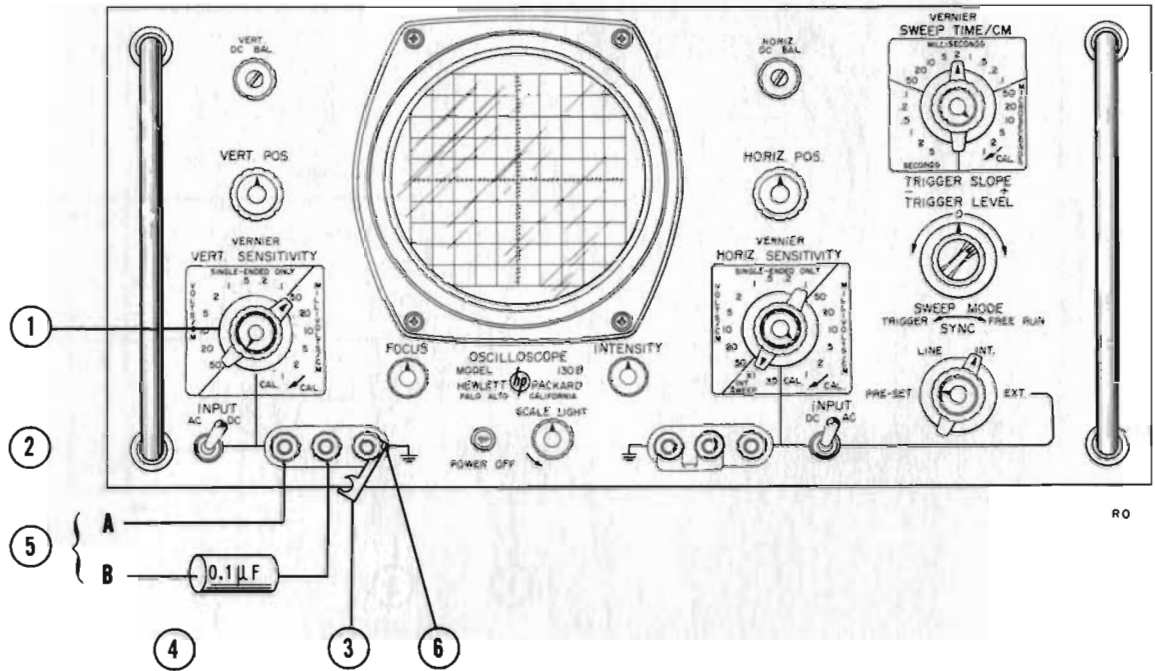

The following procedure is for the vertical input, but is the same for the horizontal input.

1. Set VERT. SENSITIVITY to 50 MILLIVOLTS/CM, input not balanced on higher ranges.
2. Set AC-DC switch to AC.
3. Disconnect shorting strap.

4. Connect 0.1 microfarad capacitor to mid-terminal.

5. Connect input signal to A and B.
6. Ground input at the black terminal.

The capacitor must be used to block any dc.

Figure 2-7

CONNECTION TO CRT DEFLECTION PLATES

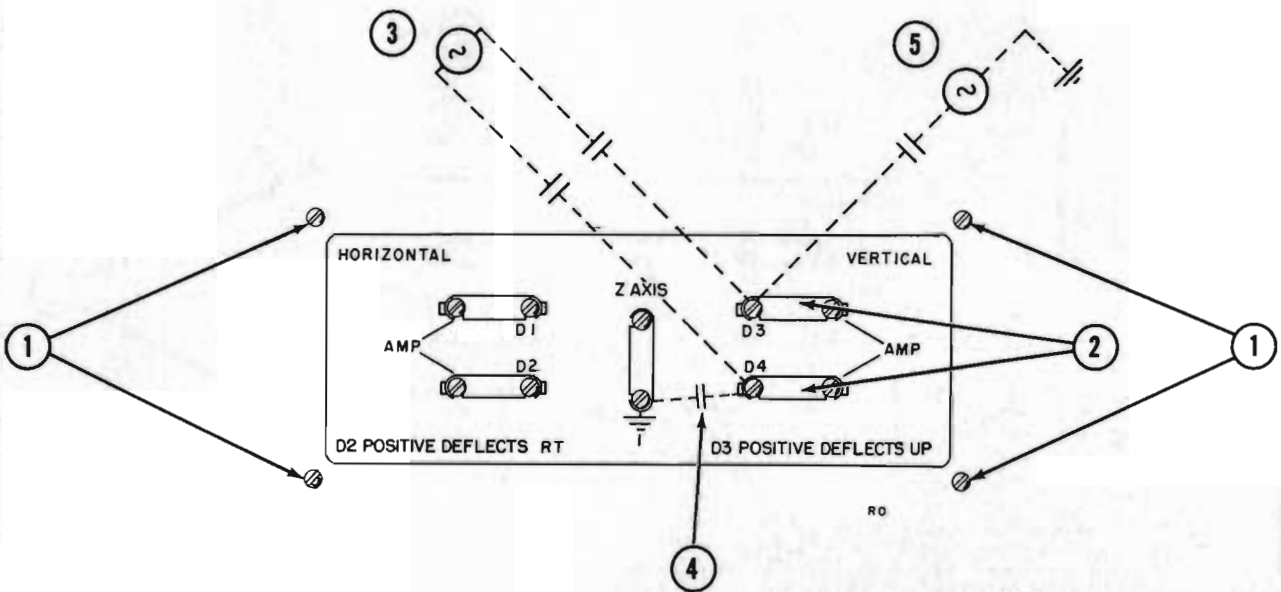

The following procedure is for connecting external signals to the vertical deflection plates, but is the same for the horizontal plates.

1. Remove rear access plate fastened by four screws.
2. Remove the shorting bars between the Vertical Amplifier and terminals D3 and D4 and replace them with 1 megohm, 1/2 watt resistor.

For balanced AC coupling:

3. Connect balanced signal through appropriate capacitor to D3 and D4.

For single-ended AC coupling:

4. Bypass D4 to chassis with an adequate capacity.
5. Connect the signal to D3 through an appropriate capacitor.

NOTE: If it is desired to have positive voltage deflect the beam downward, bypass D3 to chassis and connect the signal to D4.

Figure 2-8

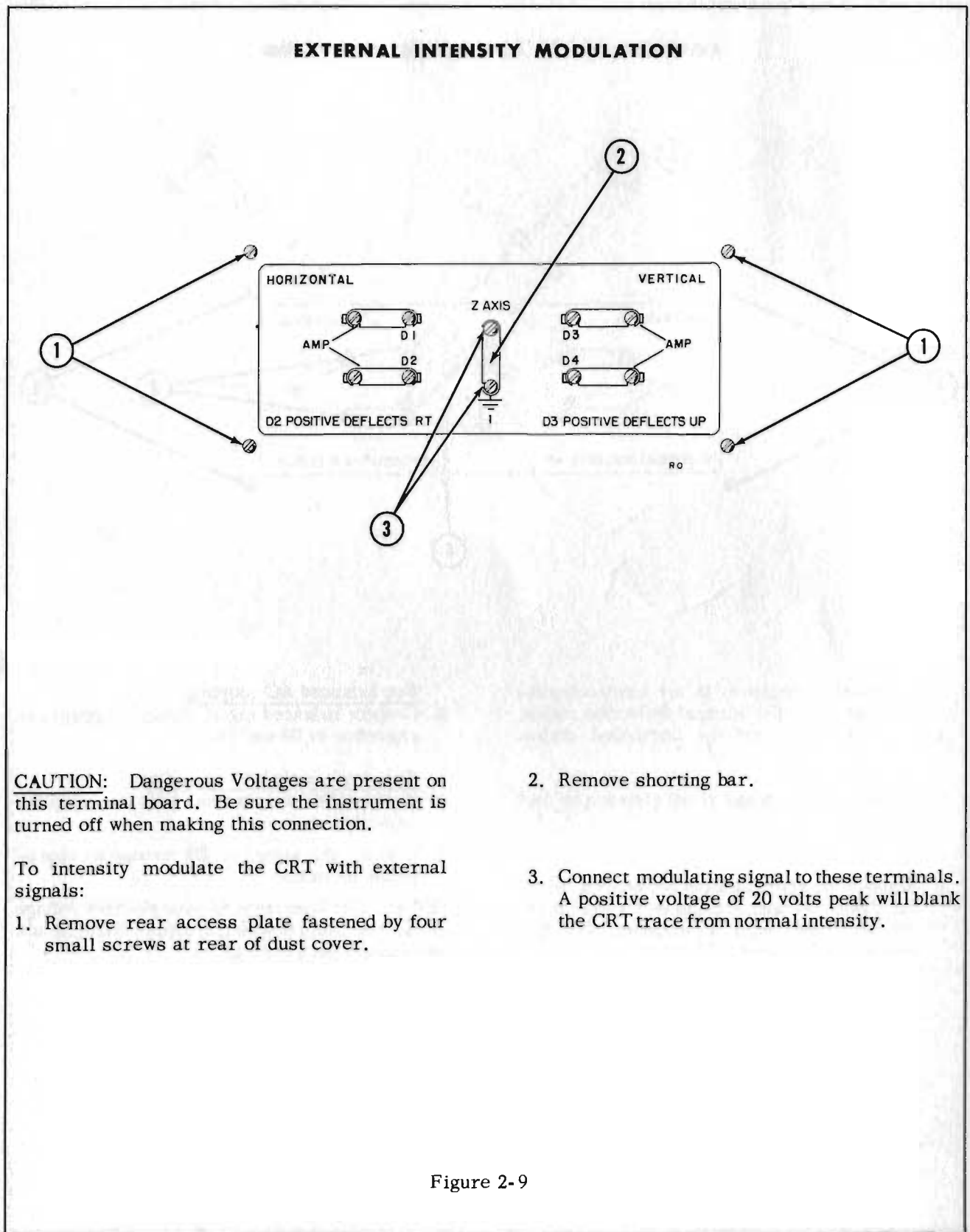

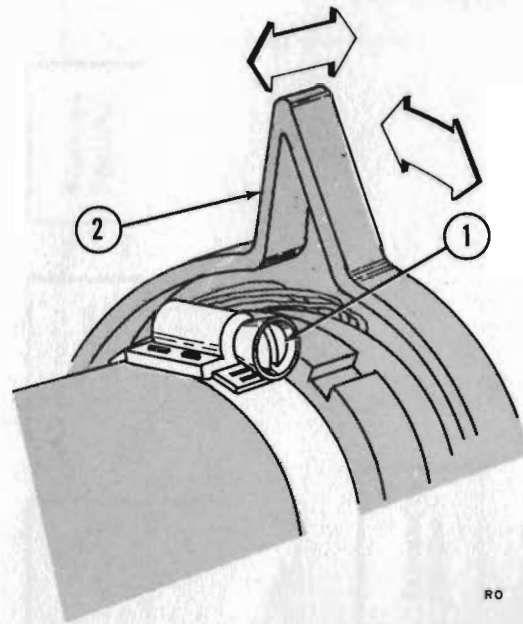
ALIGNING SCOPE TRACE WITH GRATICULE

**CAUTION: DANGEROUS VOLTAGES ARE
PRESENT INSIDE THE INSTRUMENT**

Remove two screws at rear of dust cover and slide cover off to rear. Fiber lever (2) controls both radial and longitudinal positioning of CRT and is locked by clamp (1).

To align sweep trace with graticule loosen clamp (1) with a screwdriver. Rotate fiber arm (2) until the trace is parallel to horizontal lines on graticule. Tighten clamp (1) after adjustment has been made.

Figure 2-10

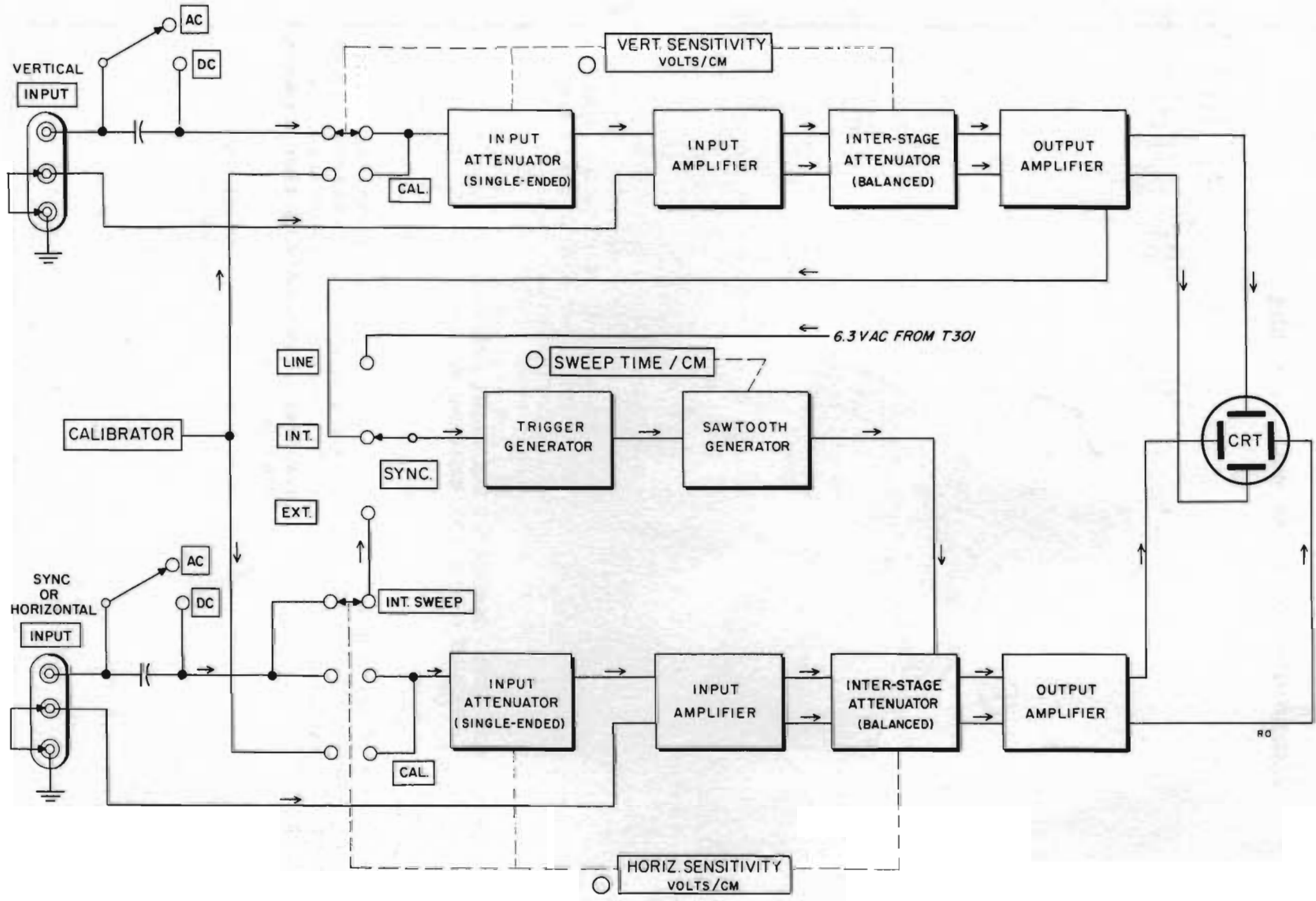

Figure 3-1. Model 130B Block Diagram

SECTION III THEORY OF OPERATION

3-1 GENERAL CONTENT

This section contains a brief description of the over-all operation of the Model 130B Oscilloscope, description of each major section and detailed description of a Schmitt trigger.

3-2 OVER-ALL OPERATION

The block diagram in Figure 3-1 shows the basic circuits of the Model 130B Oscilloscope.

A. VERTICAL AMPLIFIER

The Vertical Amplifier receives the input signal, amplifies it, and drives the vertical deflection plates of the cathode ray tube. In addition, this amplifier determines the vertical position of the spot on the screen and supplies a signal for synchronizing the sweep with the vertical input signal.

B. HORIZONTAL AMPLIFIER

The Horizontal Amplifier receives its signal either from the horizontal INPUT jack or from the Sweep Generator, amplifies it and drives the horizontal deflection plates of the cathode ray tube. Except for the provisions in the Horizontal Amplifier for amplifying the internally-generated sawtooth voltage, it is essentially the same as the Vertical Amplifier.

C. SWEEP GENERATOR

The Sweep Generator forms a sawtooth voltage to control the horizontal movement of the spot across the face of the cathode ray tube. The Sweep Generator is divided into two parts: 1) a sawtooth generator, 2) a trigger generator, which starts the sawtooth. The trigger generator controls allow the operator to choose the point at which the sawtooth sweep begins.

In addition to forming the internal sweep of the oscilloscope, the Sweep Generator also supplies the required unblanking pulse which brightens the trace during each sweep.

D. CALIBRATOR

An internal square-wave calibrator, with a nominal frequency of 300 cps, is provided for setting the basic gain of the amplifiers. Turning either the VERT. or HORIZ. SENSITIVITY switches to CAL., turns on the calibrator supply voltage and connects its output to the appropriate amplifier.

E. CATHODE RAY TUBE

The cathode ray tube is a 5AQP - mono-accelerator type. It is normally supplied with a P1 phosphor screen but is available in the P7 and P11 phosphors also and P2 upon special order. All are electrically interchangeable and the tube is easily changed. The mono-accelerator anode makes possible a simple astigmatism adjustment which requires no resetting when adjusting the FOCUS or INTENSITY controls. The deflection plate terminals are connected through removable jumpers at the rear of the instrument so that direct connections to the plates can be made easily.

3-3 VERTICAL AMPLIFICATION CHANNEL

The vertical amplification channel consists of three parts: the AC-DC switch, the input attenuator, and the amplifier section proper.

A. AC - DC SWITCH

The signal comes into the input terminals and is fed to the AC-DC switch. For ac coupling, a capacitor is switched into the signal path. In the DC position, the signal goes directly to the input attenuator.

B. INPUT ATTENUATOR

The input attenuator is a sixteen position switch having fifteen calibrated ranges (1 MILLIVOLT/CM to 50 VOLTS/CM) and a calibrate position. When the switch is in the CAL. position, the input of the amplifier is directly connected to the output of the internal calibrator. On ranges less sensitive than 50 MILLIVOLTS/CM, single-ended frequency-compensated attenuators are inserted ahead of the Vertical Amplifier. On the six most sensitive ranges, balanced-type attenuators are inserted between the second differential amplifier (V2) and the third differential amplifier (V3). On the six most sensitive ranges, balanced input signals may be applied to the input terminals after removing the jumper to the ground terminal. The sensitivity may be varied continuously between ranges by means of the VERNIER control.

C. VERTICAL AMPLIFIER

The Vertical Amplifier consists of four stages of balanced differential amplifiers* in cascade. The first stage (V1) has the VERT. DC BAL. adjustment (R10A, B) in its cathode circuit which adjusts the current division between the two halves of the stage. The second stage has a VERNIER control in the cathode circuit which varies the gain of the amplifier between ranges of the VERT. SENSITIVITY switch, and another dc balance adjustment (R20) is also provided. In the last three stages, neutralizing capacitors are used to cancel the coupling effects between the input and output of the amplifier arising from the inter-electrode capacitances. The output of the second stage is fed to the balanced attenuator of the VERT. SENSITIVITY switch. The output of the balanced attenuator is connected to the third balanced differential amplifier (V3). The third stage has two potentiometers in its cathode circuit, one controls the vertical position of the pattern (VERT. POS) and the other adjusts the basic gain of the Vertical Amplifier (R40, Gain Adj.). The fourth balanced differential amplifier (V4) is the output stage. The neon lamps in the grid-cathode circuit of V4 protect the tube when the Model 130B is first turned on. The output of V4 drives the vertical deflection plates of the cathode ray tube. In addition, synchronization signals are coupled from

* Valley and Wallman, "Vacuum Tube Amplifier", Massachusetts Institute of Technology Radiation Series, vol. 18, pp 441-451. McGraw-Hill Book Company, Inc., New York, 1948.

the plates of V4 and coupled into the Sweep Generator to trigger the sweep during either INTERNAL + or INTERNAL - synchronization. As a precaution against drift and hum, a regulated dc supply is used for the heaters of the first three stages.

3-4 HORIZONTAL AMPLIFICATION CHANNEL

The Horizontal Amplifier is essentially identical to the Vertical Amplifier, except in the INT. SWEEP X1 and X5 position of the HORIZ. SENSITIVITY switch. In these positions, the sawtooth signal from the Sweep Generator is fed through the sweep attenuator to the grid of V103, the third balanced differential amplifier. In the INT. X5 position, R164, X5 Mag. Adj., in the cathode circuit of V104 sets the gain of the amplifier to obtain sweep magnification of X5. The output of V104 drives the horizontal deflection plates of the cathode ray tube.

3-5 SWEEP GENERATOR

The sweep generator provides a sawtooth voltage to produce linear horizontal movement of the spot across the face of the cathode ray tube when the HORIZ. SENSITIVITY switch is set to INT. SWEEP (X1 or X5). In addition, the sweep generator furnishes the pulse required to unblank the cathode ray tube during each sweep.

The sweep generator consists of a Trigger Generator, a Sawtooth Generator, and a Gate Out Cathode Follower.

A. TRIGGER GENERATOR

The purpose of the Trigger Generator is to receive a synchronizing signal and convert it into a fast, constant-amplitude pulse to start the Sawtooth Generator.

The Trigger Generator consists of a SYNC selector switch (S201), a Trigger Amplifier (V201), and a Trigger Generator (V202). The SYNC selector switch accepts a signal from:

- 1) the Vertical Amplifier (internal synchronization, + or -),
- 2) an internal 6.3 volt source (line-frequency synchronization), or
- 3) the horizontal INPUT terminals (external synchronization).

The synchronizing signal is fed to V201 which amplifies the signal and delivers it in the proper phase, as selected by the TRIGGER SLOPE switch, to the Trigger Generator. Adjustment of the TRIGGER LEVEL control sets the output level of V201, determining the point on the input waveform that will trigger the Trigger Generator (V202). Trigger Generator (V202) is a Schmitt trigger circuit; a discussion of the Schmitt trigger follows:

A Schmitt trigger consists of two amplifiers, A and B, having both plate-to-grid and cathode-to-cathode coupling. The circuit has two stable states: A side conducting, B side cut off; B side conducting, A side cut off. Due to regenerative action the change-over from one state to the other is very rapid, producing fast rise and decay times in the square-wave output. The levels at which the change-over takes place (hysteresis limits) can be adjusted to be close together as in the Trigger Generator (V202) or widely spaced as in the Start-Stop Trigger (V203). To trigger the circuit, the A side grid voltage must cross a particular hysteresis limit to change the state of the circuit. For example, if the A side is conducting, driving the grid voltage positive through the upper hysteresis limit will have no effect, but driving the grid voltage negative through the lower hysteresis limit will put the A side out of conduction and B side into conduction.

B. SAWTOOTH GENERATOR

The Sawtooth Generator consists of Start-Stop Trigger (V203), and Integrator Switch (V205), a Feedback Integrator (V206B), and Integrator Cathode Follower (V206A), and a Retriggering Hold-Off Cathode Follower (V207B).

Start-Stop Trigger (V203), a Schmitt trigger circuit, is fed by Trigger Generator (V202). The square wave output of V203 is fed directly to the Integrator Switch (V205), which in turn controls the action of Feedback Integrator (V206B). When V203 produces a negative pulse, it causes V205 to cut off permitting V206B to commence operation.

Feedback Integrator (V206B), a Miller integrator circuit*, generates essentially a positive linearly rising waveform, which is applied to the Horizontal Amplifier to sweep the trace across the face

of the cathode ray tube. The rate at which this sweep takes place is determined by the values of the RC network in the grid circuit of V206B. These values are varied by the SWEEP TIME switch. The output of V206B is fed through a neon lamp (I203) to the Integrator Cathode Follower (V206A). Neon lamps (I204 to I206) are used to drop the voltage to the proper level and at the same time furnish a direct-coupled path for the signal. The neon lamps are shunted with a capacitor to improve the high-frequency response of the circuit, and a series resistor is used to eliminate any tendency toward oscillation.

The output of the Integrator Cathode Follower (V206A) is fed to two circuits: 1) through the sweep attenuator to the Horizontal Amplifier and 2) to the Retriggering Hold-Off Cathode Follower (V207B) in the Sawtooth Generator feedback circuit. During the Sweep, V207B conducts and the capacitor in its cathode circuit charges. However, at the termination of the sweep, V207B is cut off and the cathode capacitor discharges, maintaining a positive bias on the grid of V203A. This hold-off bias allows sufficient time between sweeps for the Sweep Generator to recover. The bias which determines the triggering level of the Start-Stop Trigger (V203A) is supplied by the Retriggering Bias Control (V207A). The bias is adjusted by the SWEEP MODE control, R218, in the grid circuit of V207A.

C. GATE OUT CATHODE FOLLOWER

Another function of the Start-Stop Trigger is to furnish a pulse to unblank the cathode ray tube. The Gate Out Cathode Follower (V204), couples the required positive unblanking pulse from the Start-Stop Trigger to the grid of the crt for the duration of the sweep.

3-6 **LOW VOLTAGE POWER SUPPLY**

The low-voltage power supply consists of four regulated voltage supplies, three positive (+585V, +300V, +100V) and one negative (-150V), furnishing the plate voltages and dc filament voltages required for the instrument.

The operation of each of the four regulators is similar; only the -150 volt supply will be discussed. V306, V307 and V308 constitute the voltage regulator circuit for the -150 volt supply. V308, a glow discharge tube, provides a fixed reference voltage for the cathode of V307, the

* Millman and Taub, "Pulse and Digital Circuits" pp 216-228, McGraw-Hill Book Company, Inc., New York, 1956.

Control Tube. V306 operates as the regulator tube (or variable resistor), controlled by the voltage at the plate of V307. If the regulated output from the cathode of V306 tends to increase, the voltage at the grid of V307 tends to increase, causing V307 to draw more current. This lowers the plate voltage of V307 and the grid voltage of V306, resulting in greater plate resistance for V306. Increased plate resistance causes a greater voltage drop across V306, compensating for the increased output voltage from the regulator and resulting in a substantially constant output.

If the regulated output tends to decrease, the reverse of the above action occurs, tending to maintain the output voltage constant. In the same manner, changes in voltage at the screen of V307 compensate for variations and ripple in the input (unregulated) voltage. The output of the -150 volt supply serves as the reference voltage for the three positive-voltage supplies.

3-7 HIGH-VOLTAGE POWER SUPPLY

The high-voltage power supply provides regulated dc voltage to the cathode and control grid of the cathode ray tube. The high-voltage power supply consists of an RF Oscillator tube (V313), a high-voltage transformer (T302), high-voltage rectifiers (V310,311) and a High-Voltage Control Tube (V312). The RF Oscillator, a Hartley circuit, oscillates at a frequency of approximately 100 kc. The high-voltage transformer has two separate secondaries which feed the High-Voltage Rectifiers.

The output of V310 is connected to the cathode of the cathode ray tube. A fraction of this voltage is fed to the High-Voltage Control Tube V312, a dc-coupled amplifier. The output of V312 is fed back to the screen of RF Oscillator tube (V313) in proper phase to oppose any change in the high-voltage output. The INTENSITY control in the output of this supply determines the voltage on the cathode of the cathode ray tube.

The output of V311 is connected to the control grid of the cathode ray tube, and normally the crt beam is cut off. During the sweep operation, a positive

pulse from the Gate Out Cathode Follower (V204) in the Sweep Generator circuit overrides the negative crt grid cutoff voltage and unblanks the cathode ray tube. The brilliance of the trace may be adjusted with the Intensity Adjust potentiometer (R343), in series with grid-voltage supply.

3-8 CALIBRATOR

The Calibrator, a square-wave oscillator, produces an accurate voltage across R244 for application to either amplifier for setting the basic gain. Turning either the VERT. or HORIZ. SENSITIVITY switches to CAL. turns on the Calibrator and connects its output to the appropriate amplifier.

The Calibrator consists of two neon lamps (I207 and I208) in a relaxation oscillator circuit. Operation of the Calibrator is as follows:



When the +300 volt supply is applied to the Calibrator, I207 will ionize first due to higher potential across it compared to the potential across I208. When I207 fires it will draw current through R243. However, the voltage at the junction of R242, C213 and R243 will build up slowly because the voltage across a capacitor cannot change instantaneously. As C213 allows this voltage to change, the voltage at the common junction of I207 and I208 will also change, since the voltage drop across the ionized neon lamp is constant (approximately 60 volts). As the voltage at the common junction of I207 and I208 reaches approximately +70 volts, I208 will fire. This additional current through R240 and R241 will reduce the voltage across I207 and it will de-ionize. I208 remains lit until the voltage across C213 charges through R243 to a voltage approximately 70 volts below the voltage that appears at the common junction of I207 and I208. I207 will now fire and the action will repeat itself.

I208 is thus alternately turned off and on at a rate of approximately 300 cps. The output of the Calibrator is taken from the current passing through R244 and I208. The output is approximately a square wave which can be set with R240 to obtain 300 millivolts in amplitude.



SECTION IV MAINTENANCE

4-1 INTRODUCTION

This section contains instructions for testing, adjusting, and trouble shooting the Model 130B Oscilloscope.

Standard, readily available components are used for manufacture of  instruments whenever possible. Special components are available through your local  Representative who maintains a part stock for your convenience.





When ordering parts, specify instrument model and serial number plus the component description and stock number appearing in the Table of Replaceable Parts.

Your local  Representative maintains complete facilities and specially trained personnel to assist you with any problems you may have with  instruments.

The material in this section is divided according to circuit functions, each section having a complete set of adjustment instructions. The material in this section is as follows:

- 4-2 Simple Check Procedure
- 4-3 Isolating Troubles to Major Sections
- 4-4 Removing the Cabinet
- 4-5 Connecting for 230 Volt Operation
- 4-6 Tube Replacement
- 4-7 Condensed Test and Adjustment Procedure
- 4-8 Adjustment Procedure
- 4-9 Turn On
- 4-10 Power Supplies
- 4-11 Replacing and Adjusting the CRT
- 4-12 Checking and Adjusting the Calibrator
- 4-13 Adjusting the Vertical Amplifier
- 4-14 Adjusting the Horizontal Amplifier
- 4-15 Phase Shift Adjust
- 4-16 Adjusting Preset
- 4-17 Adjusting the Sawtooth Generator and Sweep Amplifier

The following test equipment is used for testing and adjusting the Model 130B Oscilloscope during manufacture. Equivalent test equipment may be used.

- 1) A high impedance dc vacuum tube voltmeter, such as an  Model 410B with an  Model 459A DC Voltage Multiplier, calibrated to an accuracy of $\pm 1\%$.
- 2) A high impedance ac vacuum tube voltmeter, such as an  Model 400D/H/L.
- 3) A variable power line transformer with a minimum rating of 3 amps.
- 4) A square-wave generator such as an  Model 211A.
- 5) A sine-wave oscillator with a maximum frequency of at least 500,000 cycles, such as an  Model 200CD.
- 6) An accurate time mark generator suitable for sweep speed calibration.

4-2 SIMPLE CHECK PROCEDURE

This check should be performed first whenever instrument malfunction is suspected. It is not necessary to remove the instrument from the cabinet.

Set both VERT. and HORIZ. SENSITIVITY switches on CAL. The pattern should be a straight line tilted at 45 degrees. In addition, the deflection should be a total of six centimeters in the horizontal and vertical directions.

If the proper pattern is obtained, it is likely that both the Vertical and Horizontal Amplifier, the Power Supplies and the Calibrator are functioning properly. To check the Sweep Generator proceed as follows:

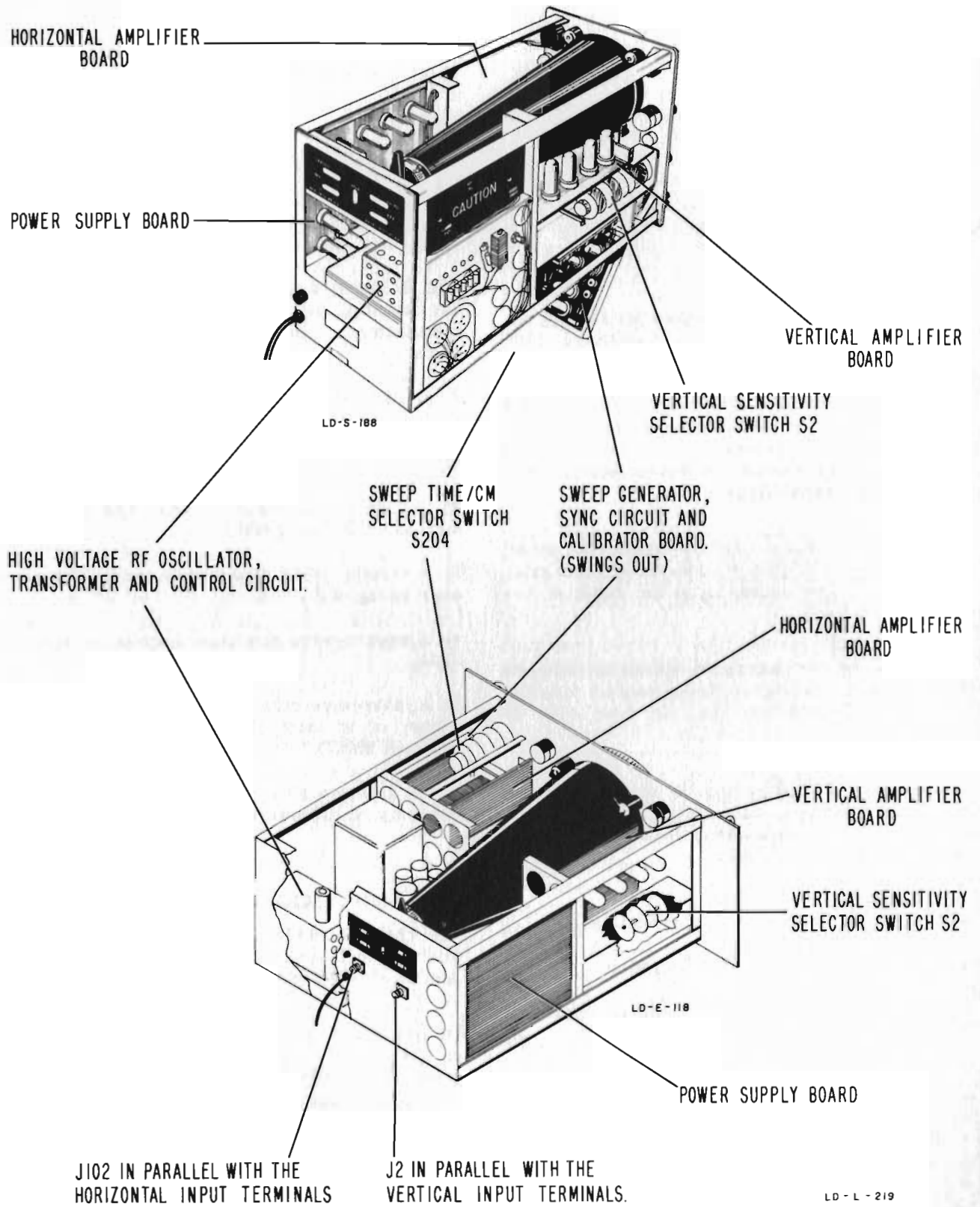

Figure 4-1. Location Diagram for Major Circuits

1) Leaving the VERT. SENSITIVITY switch in CAL, switch HORIZ. SENSITIVITY switch to INT. SWEEP X1.

2) Switch SWEEP TIME/CM switch to 1 MILLI-SECOND. A six centimeter square-wave pattern should appear on the screen. If no pattern is obtained be sure SWEEP MODE is in PRESET, SYNC switch is in INT., and adjust TRIGGER LEVEL to trigger. If a pattern cannot be obtained, the malfunction is most likely in the Sweep Generator.

4-3 ISOLATING TROUBLES TO MAJOR SECTIONS

Determining which major section contains a malfunction is usually not a difficult process, if the following general rules are remembered.

1) A failure affecting all major sections can usually be traced to the power supply.

2) A failure occurring in the last two stages of the Horizontal Amplifier also will affect internally generated sweeps, while a failure in the first two stages affects only the Horizontal Amplifier.

3) A sweep Generator failure affects internally generated sweeps only, and does not affect the Horizontal Amplifier.

4) If following the Simple Check Procedure does not produce a trace or spot on the screen, measure the voltages on the deflection plates of the Cathode-Ray Tube (deflection plate terminal board is a convenient place to measure). If, with both VERT. and HORIZ. SENSITIVITY switches set to 50 MILLIVOLTS/CM, these voltages can be set to approximately 480 vdc using the position controls, look for trouble in the high voltage section of the power supplies. If one set of deflection plates has unbalanced voltages, or if the position control must be turned far from its mechanical center to balance these voltages, look for trouble in that amplifier. If both sets of deflection plates have unusual voltages, look for trouble in the power supply.

5) If the series heater string should open, all major sections will be inoperative.

6) The two sides of the direct-coupled differential amplifier, such as are used in the Vertical and Horizontal Amplifiers on the 130B, are balanced and, unless a signal is present, the spot will be motionless in the center of the screen. Any signal,

whether this signal is applied to the input terminals or is supplied by an internal source, such as a positioning or balance control, causes the spot to move from the center of the screen. As the instrument ages it is to be expected that a drift will occur which must be compensated by internal adjustments. However, should there be a component failure in either amplifier the spot will be thrown off the screen and usually out of range of adjustment of the balance and positioning controls. To isolate the trouble, begin by shorting together the grids of the amplifier closest to the output. If the trace (spot) returns to the screen, the fault is ahead of this stage. Proceed towards the front of the amplifier. If shorting the grids of one stage does not return the spot to the screen, the fault is in this stage, or if there is a balancing control in this stage, it may be out of adjustment.

7) To check the Sweep Generator quickly, set the SWEEP TIME/CM switch to 5 or 10 MILLI-SECONDS/CM, turn the SWEEP MODE control to FREE RUN, and observe I201, I202 and I203. These are the three neon lamps near V206 (6AW8) on the Sweep Generator etched circuit board. If these lamps flicker regularly, the Sweep Generator is sweeping. Turning the SWEEP MODE into the TRIGGER region should stop the generation of sweeps and, hence, the flickering of the neon lamps.

4-4 REMOVING THE CABINET

In the cabinet model, remove the two screws at the rear of the cabinet, and push the instrument forward.

If the 130BR has been rack-mounted with brackets as described in Figure 1-1, remove the screws which pass through the front panel, and withdraw the chassis. If the instrument is out of the rack, turn it on its face (handles will protect the controls), remove the two screws at the rear, and lift off the dust cover.

4-5 CONNECTING FOR 230 VOLT OPERATION

Unless otherwise requested by the customer, Φ instruments are shipped with their power transformer primaries connected in parallel for operation on 115 volt (nominal) power lines.

To convert to 230 volt supply, remove the instrument from its cabinet or dust cover by removing the two screws at the rear of the chassis, and

push the chassis forward. At the primary of the power transformer (marked A), remove the wires connecting terminals 2 and 5, and 1 and 4. Then connect 1 to 2 as shown in Figure 4-2, and replace the 2 amp slow-blow fuse (F301) with a 1-1/4 amp slow-blow fuse. The instrument may now be connected to the 230 volt line.

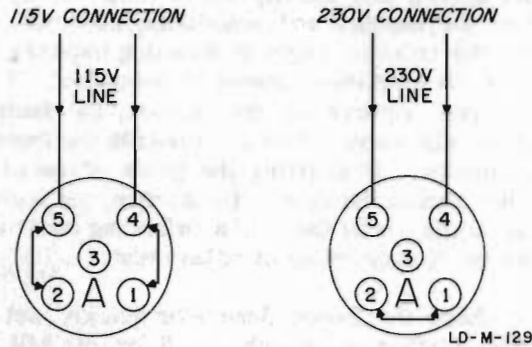

Figure 4-2. Line Voltage Connection

4-6 TUBE REPLACEMENT

In many cases instrument malfunction can be corrected by replacing a weak or defective tube. Before changing the setting of any internal adjust-

ment, check the tubes. Adjustments made in an attempt to compensate for a defective tube will often complicate the repair problem.

It is a good practice to check tubes by substitution rather than by using a "tube checker". The results obtained from the "tube checker" can be misleading. Before removing a tube, mark it so that if the tube is good it can be returned to the same socket. Replace only tubes proved to be weak or defective.

Any tube with corresponding standard EIA (JEDEC) characteristics can be used as a replacement. Where variation in tube characteristics will affect circuit performance, an adjustment is provided. The following table lists the tests and adjustments which should be performed if such tubes are replaced.

The chart in Table 4-2 lists all tubes in the 130B with their functions and adjustments required when replacing tubes. The heaters of some tubes are operated in series from a regulated dc voltage obtained from the Low-Voltage Power Supply. These tubes are identified in the chart with an asterisk and their heaters are shown in the Filament and Primary Detail Schematic. If a tube in the dc string is pulled or burned out, all tubes in the string will be turned off.

4-7 CONDENSED TEST AND ADJUSTMENT PROCEDURE

All basic tests and adjustments are covered in the following Table 4-1. In most cases, this table will cover all normal adjustment needs for the oscilloscope. For a more complete and de-

tailed test procedure refer to paragraph 4-8.

If the instrument is not operating, refer to paragraphs 4-3 and 4-6.

If a tube is replaced, refer to Table 4-2 and complete the indicated adjustments.

TABLE 4-1. CONDENSED TEST AND ADJUSTMENT PROCEDURE

Test	External Equipment Required	Procedure	Adjust	Notes
1. Low Voltage Power Supply	DC vtvm with 1% accuracy	Measure all low voltage power supply outputs should be within the following limits: -150 ± 6 volts +100 ± 4 volts +300 ± 12 volts +585 ± 25 volts	If voltages are outside limits, adjust R332 for -150 volts.	Check sweep calibration if -150V is adjusted.
2. Vertical amplifier balance	NONE	HOR.SENS. to INT.SWEEP X1, SWEEP MODE to free-run, SYNC to INT., SWEEP TIME to 1.0 ms/cm, short-circuit input terminals and set INPUT for DC. VERT.SENS. and Vernier to Cal.	Center bottom of calibrating signal with VERT.POS. control	Repeat as required.
		VERT.SENS. to 1 mv/cm, Center VERT.DC.BAL control (knob).	Center trace with coarse balance control. (Screw adjustment in center of DC BAL control.)	
3. Vertical VERNIER balance	NONE	Short circuit input terminals and set INPUT for DC. VERT.SENS. to 1 mv/cm, VERNIER to Cal.	Center spot (or trace) with VERT. POS. control.	Repeat as required.
		VERNIER fully CCW	Return spot to center with R20	
4. Vertical amplifier gain	400 cycle Voltage Calibration Generator	VERT.SENS. to 50 mv/cm. VERNIER to Cal. Connect 300 mv p-p from Calibration Generator to vertical input.	Adjust R40 for 6 cm deflection.	
	Square Wave Generator	Connect 50 kc square wave to Vert. Input. Adjust square wave generator for 6 cm deflection. SYNC to INT, Adjust SWEEP MODE and TRIGGER LEVEL for stable picture.	Adjust C12 for best square wave.	
5. Calibrator	NONE	VERT.SENS. and VERNIER to CAL, SWEEP MODE to free-run; SWEEP TIME to 1 ms/cm.	Adjust R240 for 6 cm deflection.	
6. Horizontal amplifier balance	NONE	Short-circuit input terminals and set INPUT for DC. VERT.SENS. to 50 mv/cm, with no input. HOR.SENS. and VERNIER to CAL.	Center the left spot with the HOR.POS. control.	Repeat as required.
		HOR.SENS. to 1 mv/cm, Center the HOR.DC BAL control (knob).	Center the spot with the coarse balance control (screw driver adjustment in center of DC BAL control).	
7. Horizontal VERNIER balance	NONE	Short-circuit input terminals and set INPUT for DC. HOR.SENS. to 1 mv/cm, VERNIER to CAL.	Center spot with POS. control HORIZ.	Repeat as required.
		VERNIER fully CCW.	Return spot to center with R120.	
8. Horizontal amplifier gain	NONE	HOR.SENS. and VERNIER to CAL.	Adjust R144 for 6 cm between spots.	
	Square wave generator	HOR.SENS. to 50 mv/cm, Connect 50 kc square wave to Hor. input and adjust for 6 cm deflection.	Adjust C114 for best defined spots.	
9. Sweep gain	Time Marker Generator	HOR.SENS. to INT.SWEEP X1 SWEEP TIME to 1 ms/cm, VERNIER to CAL; 1 kc markers from generator to VERT. input. SYNC to INT. Adjust SWEEP MODE and TRIG.LEVEL for stable pattern.	Adjust R134 for one marker/cm	
		HOR.SENS. to INT.SWEEP X5.	Adjust R164 for markers 5 cm apart.	
10. Sweep preset	DC VTVM	HOR.SENS. to INT.SWEEP X1. SWEEP TIME to 1 ms/cm, SWEEP MODE to PRE-SET, SYNC to EXT. with no input. Connect VTVM 30 volt range between center arm of Preset pot (R220) and ground.	Slowly adjust R220 and note voltage just prior to sweep start. Adjust pre-set for 2 volts more positive than voltage noted.	
11. Sweep length	Sine Wave Oscillator	HOR.SENS. to INT.SWEEP X1. SWEEP TIME to 1 ms/cm. SYNC to INT. Connect 500 kc sine wave to vertical input. Adjust level and VERT SENS. to produce 6 cm vertical deflection.	Adjust R229 for a trace about 10.5 cm long.	

TABLE 4-2. TUBE REPLACEMENT CHART

Ref.	Tube	Function	Adjustment
<u>VERTICAL AMPLIFIER</u>			
V1*	12AU7†	Phase Inverter Amplifier	Vertical Amplifier (par. 4-13A/B)
V2*	12AU7	Differential Amplifier	Vertical Amplifier (par. 4-13A/B)
V3*	12AT7	Differential Amplifier	Vertical Amplifier (par. 4-13B)
V4*	6DJ8/6BQ7	Differential Amplifier	Vertical Amplifier (par. 4-13B)
<u>HORIZONTAL AMPLIFIER</u>			
V101*	12AU7†	Phase Inverter Amplifier	Horizontal Amplifier (par. 4-14A/B)
V102*	12AU7	Differential Amplifier	Horizontal Amplifier (par. 4-14A/B)
V103*	12AT7	Differential Amplifier	Horizontal Amplifier (par. 4-14B)
V104*	6DJ8/6BQ7	Differential Amplifier	Sawtooth Generator (par. 4-17)
<u>SWEEP GENERATOR</u>			
V201*	6DJ8/6BQ7A	Trigger Amplifier	none
V202	12AT7	Trigger Generator	none
V203	6U8	Sweep Start-Stop Trigger	Adj. Preset, Sweep Length (par. 4-15 & 4-16)
V204	6C4	Gate Out Cathode Follower	none
V205*	12AL5	a. Integrator Switch b. Integrator Switch	none
V206	6AW8	a. Integrator Cathode Follower b. Feedback Integrator	none
V207	12AX7	a. Retriggering Hold Off b. Retriggering Bias Control	none
<u>POWER SUPPLY</u>			
V301	12B4	+300-volt Series Regulator	none
V302	6AU6	+300-volt Control Tube	none
V303	12B4	+100-volt Series Regulator	none
V304*	6BH6	+100-volt Control Tube	none
V305	6X4	-150-volt Rectifier	none
V306	12B4	-150-volt Series Regulator	none
V307*	6BH6	-150-volt Control Tube	none
V308	5651	Reference Tube	LV Supply (par. 4-10A)
V309	5AQP	CRT	Adj. Vert. & Horiz. Gain (par. 4-13, 4-14)
V310	1V2	High Voltage Rectifier	none
V311	1V2	High Voltage Rectifier	none
V312	12AU7	High Voltage Control Tube	none
V313	6AQ5	RF Oscillator	none
V314	6DJ8/6BQ7A	a. +585-volt Series Regulator b. +585-volt Control Tube	none none
* Series dc heater		† Tested part - See Table of Replaceable Parts	

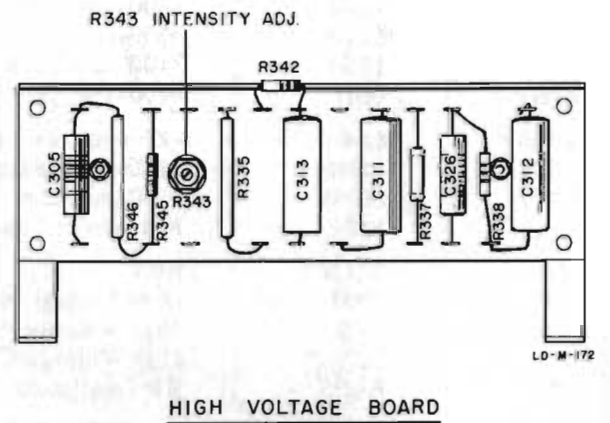
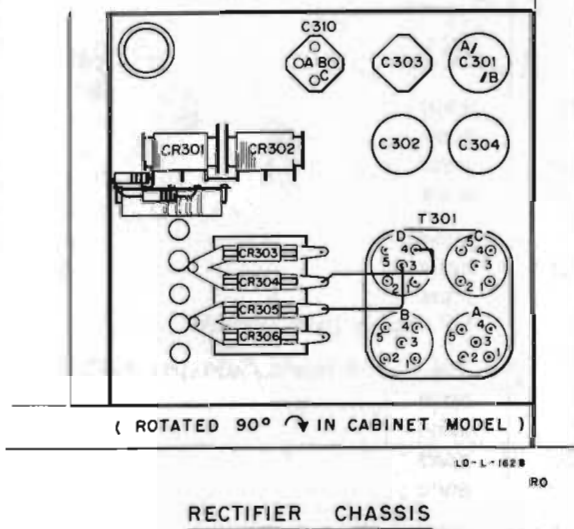
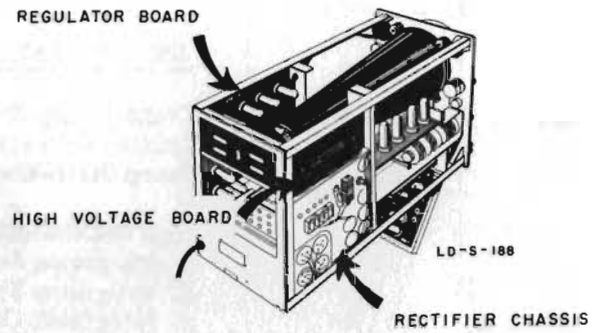
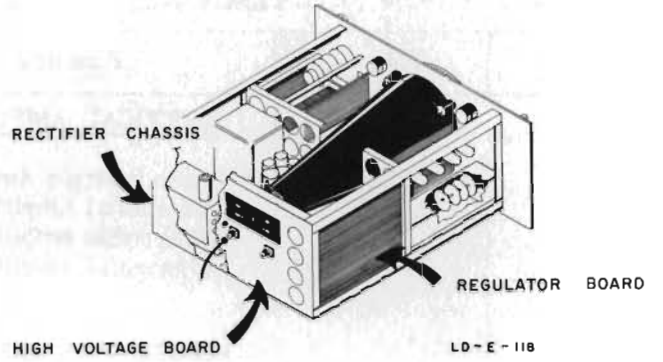
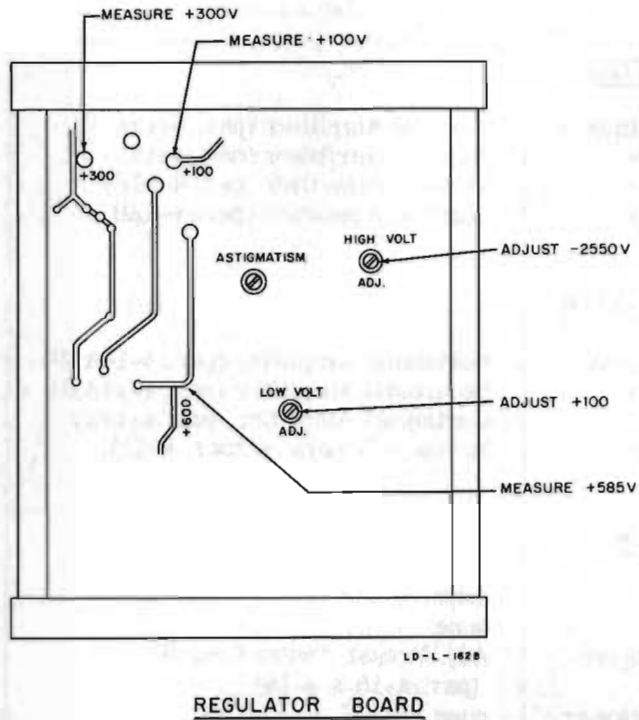

Figure 4-3. Power Supply Location Diagram

4-8 ADJUSTMENT PROCEDURE

Usually a particular oscilloscope will not need complete testing and calibration. Only one or two tests will be needed and they can be done without completing the entire test procedure.

The following procedures are listed in a recommended sequence for a complete test and calibration operation. In general, tubes are the main cause of trouble and new ones should be tried before making adjustments or other component replacements.

Specifications for the ϕ Model 130B Oscilloscope are given in the front of this manual. The following test procedures contain extra checks to help you analyze a particular instrument. These extra checks and the data they contain can not be considered as specifications.

A fifteen minute warm-up and power supply output voltage measurements are always recommended before making any other test or adjustment.

4-9 TURN ON

When turning the oscilloscope on for the first time after repair in any circuit, measure resistance from power supplies to ground. They usually will be within 25% of the following:

+100 volt supply	110 ohms
-150	50,000 ohms
+300	9,000 ohms
+585	85,000 ohms

CAUTION

When first turning an oscilloscope on after power supply repairs, turn the intensity and both positioning controls full counterclockwise before applying power. Failure to follow this precaution can cause permanent cathode-ray tube damage.

4-10 POWER SUPPLIES

The power supplies in the oscilloscope are extremely stable and will require infrequent adjustment. The output voltages should be measured at regular intervals but unnecessary adjustments should be avoided.

Power supply voltages may be measured at the points indicated in Figure 4-3.

To adjust the power supply section, refer to Figure 4-3, and proceed as follows:

A. LOW VOLTAGE SUPPLY

- 1) Turn sweep generator off by turning the HOR. SENS. switch to 50 volt/cm position.
- 2) Permit the 130B to warm up for at least five minutes at a line voltage of 115/230 volts.
- 3) Measure power supply voltages with line volts set to 115 volts. The voltages will normally be within the limits given in Table 4-3. Control R332 can be adjusted if necessary to set the +100 volt supply within limits.

If adjustment of the +100 volt supply was necessary, all sweep timing, calibrator and gain adjustments must be checked.

If poor low voltage supply regulation is suspected, the following check may be made:

- Check the regulation of each power supply voltage as the power line voltage is varied between 103 and 127 volts. All regulated voltages should remain within $\pm 1\%$ over this range of line voltage.
- Measure the ac ripple on each supply voltage. This ac voltage should not exceed the amount specified in Table 4-3.

TABLE 4-3. REGULATED POWER SUPPLY TOLERANCES

Supply	Tolerance (115/230 volt line)	Variation $\pm 10\%$ line voltage change	Nominal Ripple at 115/230V
+100 V	$\pm 4\%$	$\pm 1\%$	5 mv
-150 V	$\pm 4\%$	$\pm 1\%$	5 mv
+300 V	$\pm 4\%$	$\pm 1\%$	5 mv
+585 V	$\pm 4\%$	$\pm 1\%$	60 mv

If any output does not regulate or has excessive ripple, replace the Series Regulator Tube or the Control Tube of that supply. It must be kept in mind, however, that loss of regulation of the -150 volts will cause the other supplies to lose regulation, and that loss of regulation of the +100 volts will cause the +585 volt and +300 volt supplies to lose regulation also.

SERVICING ETCHED CIRCUIT BOARDS

Excessive heat or pressure can lift the copper strip from the board. Avoid damage by using a low power soldering iron (50 watts maximum) and following these instructions. Copper that lifts off the board should be cemented in place with a quick drying acetate base cement having good electrical insulating properties.

Use only high quality rosin core solder when repairing etched circuit boards. NEVER USE PASTE FLUX. After soldering, clean off any excess flux and coat the repaired area with a high quality electrical varnish or lacquer.

A break in the copper should be repaired by soldering a short length of tinned copper wire across the break.

When replacing tube sockets it will be necessary to lift each pin slightly, working around the socket several times until it is free.

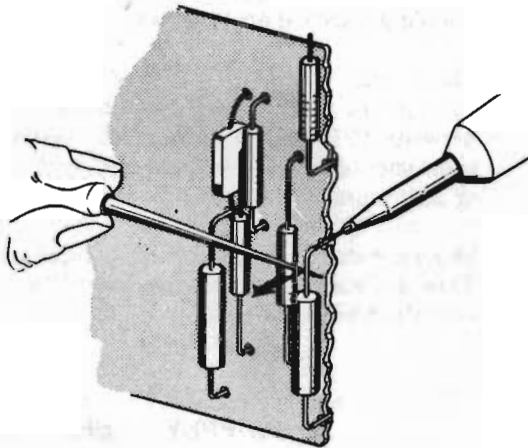

1. Apply heat sparingly to lead of part to be replaced. Remove part from card as iron heats the lead.

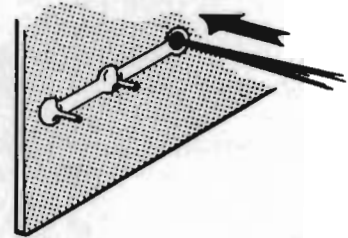

2. Using a small awl, carefully clean inside of hole left by old part.

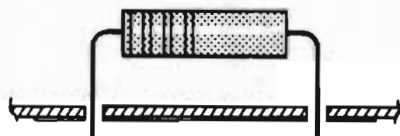

3. Bend clean tinned leads on new part and carefully insert through holes on board.

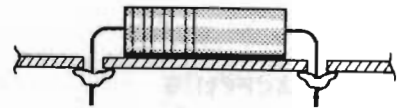

4. Hold part against board and solder leads. Avoid overheating the board.

Figure 4-4

B. HIGH VOLTAGE SUPPLY

1) The -2550 volt output is measured on the resistor board under the base of the crt. Connect an appropriate dc voltmeter (such as an Φ Model 410B VTVM with an Φ Model 459A DC Resistive Voltage Multiplier) to the Junction of R338, C312 (marked -2550 CATH. on cover).

2) With the line at 115/230 volts the high voltage should measure $-2550 \pm 4\%$. Control R334 can be adjusted if necessary to set the -2550 volt supply within limits.

If poor -2550 voltage supply regulation is suspected the following check may be made:

-- Check the regulation by varying the line voltage between 103 and 127 volts. The -2550 should remain within $\pm 1\%$ over this range of line voltage. If the -2550 supply does not regulate check the control tube V312.

3) Set SWEEP TIME/CM to 5 MILLISECONDS.

4) Set HOR. SENS. to INT. SWEEP X1.

5) Set SWEEP MODE fully clockwise to FREE RUN.

6) Set INTENSITY control to 10 o'clock.

7) Set Int. Adj., R343, until the trace is just visible.

8) Set SWEEP MODE fully counterclockwise to PRESET.

9) Set INTENSITY control for a low intensity spot.

10) Center spot and adjust FOCUS control and ASTIGMATISM (R303) to obtain a small round and sharply focused spot.

4-11 REPLACING AND ADJUSTING THE CRT

To replace the cathode-ray tube, refer to Figure 2-10, and proceed as follows:

1) Turn off and remove the 130B from the cabinet.

2) Loosen the clamp on the crt socket. (Cabinet model; remove cover from High Voltage terminal board to get access for screwdriver through board).

3) Remove the front-panel bezel.

4) With a screwdriver loosen the crt base from socket. Free the crt from the socket by pressing on the center of the tube base with one hand while supporting the front of the crt with the other.

DANGER - Do not apply force on neck of tube.

5) Remove the crt through the front panel.

CAUTION - HANDLE THE CATHODE RAY TUBE CAREFULLY.

6) Insert the replacement crt through the front panel and seat in socket.

7) Replace front-panel bezel.

8) Adjust the socket assembly so that the face of the crt just misses the bezel assembly. Tighten the clamp just enough to hold the crt in place loosely.

NOTE

Turn the INTENSITY control to minimum when first applying power to a crt. The phosphor can be damaged quickly by too much brightness.

9) Set the INTENSITY control fully counterclockwise. Turn the 130B on and allow to warm up.

10) Set the SWEEP MODE control to FREE RUN.

11) Adjust the INTENSITY control to obtain a weak trace; adjust the FOCUS control for a sharp trace, and with the vertical position control, center the trace vertically.

12) Align trace with graticule using the alignment handle at rear of crt.

CAUTION - Do not over-tighten crt clamp or tube damage may result.

13) Making certain the crt face is close to but not touching the bezel assembly, tighten the clamp on the crt socket only enough to hold the crt from turning. If the face of the tube touches the bezel assembly, Newton rings may be visible.

14) Readjust the astigmatism; see paragraph 4-10B.

15) Check the gain calibration of the Vertical and Horizontal Amplifiers by setting the VERTICAL and HORIZONTAL SENSITIVITY selectors to CAL, and if necessary, adjusting R40 (Figure 4-5) to obtain 6 cm vertical deflection and R144 (Figure 4-6) to obtain 6 cm horizontal deflection on the trace; see paragraph 4-13B and 4-14B.

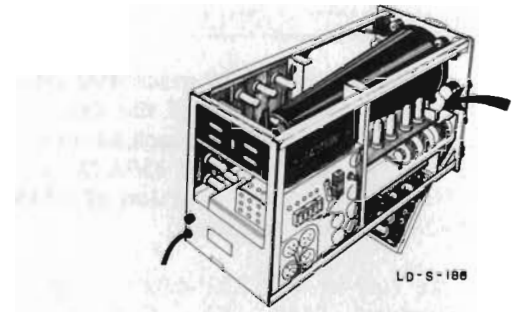
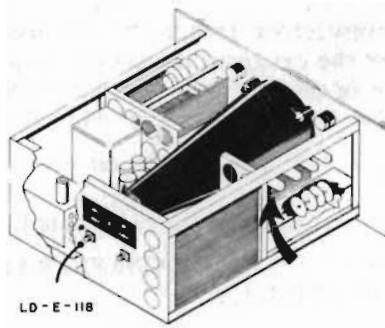

C12
ADJUST AMPLIFIER FREQUENCY
RESPONSE
(SEE PARA. 4-13B)

R40
GAIN ADJUSTMENT FOR
VERTICAL SENSITIVITY CALIBRATION
(SEE PARA. 4-13B)

R20
ADJUST VERNIER BALANCE
(SEE PARA. 4-13A)

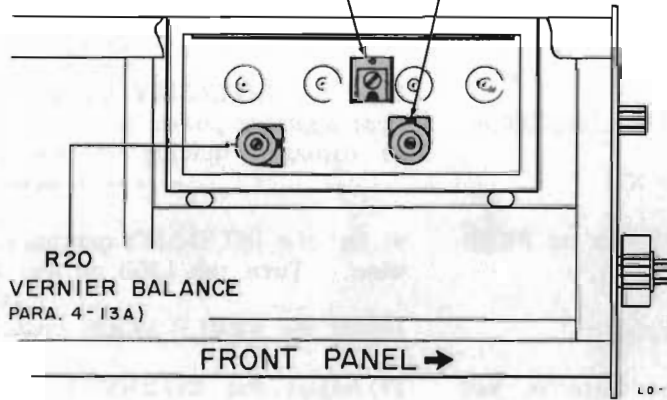

LEFT SIDE VIEW

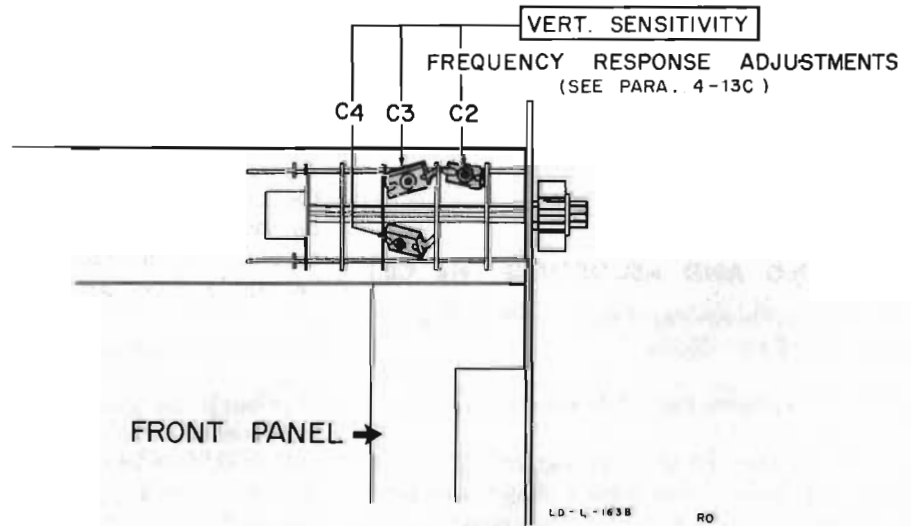

Figure 4-5. Vertical Amplifier Adjustment Location

4-12 CHECKING AND ADJUSTING THE CALIBRATOR

1) Set HORIZ. SENSITIVITY to INT. SWEEP X1; SWEEP TIME/CM to 1 MILLISECOND; SWEEP MODE to PRESET; SYNC. to INT.; and TRIGGER LEVEL to "0".

NOTE

If PRESET (SWEEP MODE) is maladjusted, you may not obtain a trace. See paragraph 4-16.

2) Set the VERT. SENSITIVITY switch to 50 MILLIVOLTS/CM. Place the VERNIER control in CAL.

3) Connect the signal source to the vertical INPUT terminals and set its rms output voltage, read on the vtvm, to 106 millivolts ($300 \text{ mv} / 2\sqrt{2}$) and its output frequency to 1000 cps.

4) Adjust R40 (see Figure 4-5) to obtain exactly 6 centimeters deflection.

5) Set the VERT. SENSITIVITY switch to CAL.

6) Adjust the R240 (see Figure 4-7) for exactly 6 centimeters deflection.

4-13 ADJUSTING THE VERTICAL AMPLIFIER

The following adjustments are located in the vicinity of the Vertical Amplifier or the VERT. SENSITIVITY switch as shown in Figure 4-5.

A. VERNIER BALANCE ADJUSTMENT

To adjust VERNIER balance, allow the instrument to warm up 15 minutes and adjust Vertical balance as shown by Figure 2-2. Then refer to Figure 4-5 and proceed as follows:

1) Short the INPUT terminals and set the INPUT switch to DC.

2) Set VERT. SENSITIVITY to 1 MILLIVOLT/CM, and VERNIER to CAL.

3) Center spot (or trace) with VERT. POS. control.

4) Turn VERNIER fully counterclockwise and return spot to center with R20, the Bal. Adj.

The trace should now be stationary as the VERNIER is rotated.

B. VERT. AMPL. GAIN AND FREQ. RESP. ADJUSTMENTS

To adjust the Vertical Amplifier gain and frequency response adjustments refer to Figure 4-5 and proceed as follows:

1) Adjust Vertical and VERNIER balance as indicated by Figure 2-2 and paragraph 4-13A.

2) Set HORIZ. SENSITIVITY to INT. SWEEP X1 and set the SWEEP TIME/CM switch to 2 MILLISECONDS, SWEEP MODE to PRESET and TRIGGER LEVEL to "0".

3) Place VERTICAL SENSITIVITY switch and its VERNIER in CAL.

4) Adjust R40 for exactly 6 centimeters deflection.

5) Set VERT. SENSITIVITY to 50 MILLIVOLTS/CM. Set SYNC to INT.

6) Set SWEEP TIME/CM switch to 5 MICROSECONDS.

7) Connect a 50 kc square wave to the Vertical INPUT and adjust the square-wave amplitude for 6 to 8 centimeters deflection.

8) Adjust C12 for best square wave. To give C12 a range of adjustment sufficient to compensate for variations of tube characteristics, C13 may be connected in parallel with C12 to increase the maximum capacity to 1340 μf .

C. INPUT ATTENUATOR FREQUENCY RESPONSE ADJUSTMENTS

To adjust frequency response of the input attenuator refer to Figure 4-5 and proceed as follows:

1) Connect a 5 kc square wave to the Vertical INPUT.

2) Set SWEEP TIME/CM to obtain 3 or 4 cycles of the square wave.

3) Make the indicated adjustment for best square-wave presentation on the following ranges:

<u>VOLT/CM</u>	<u>ADJUST</u>
10	C2
1	C4
.1	C3

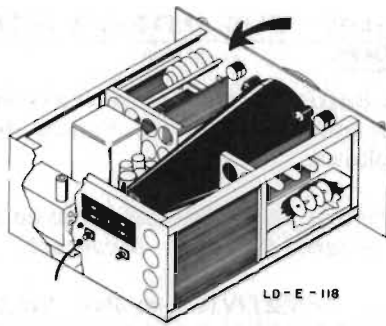

LD-E-118

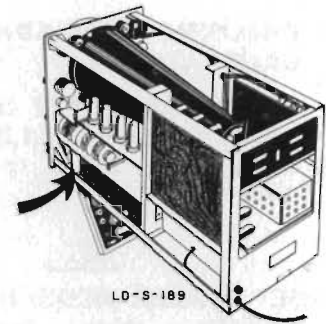

LD-S-189

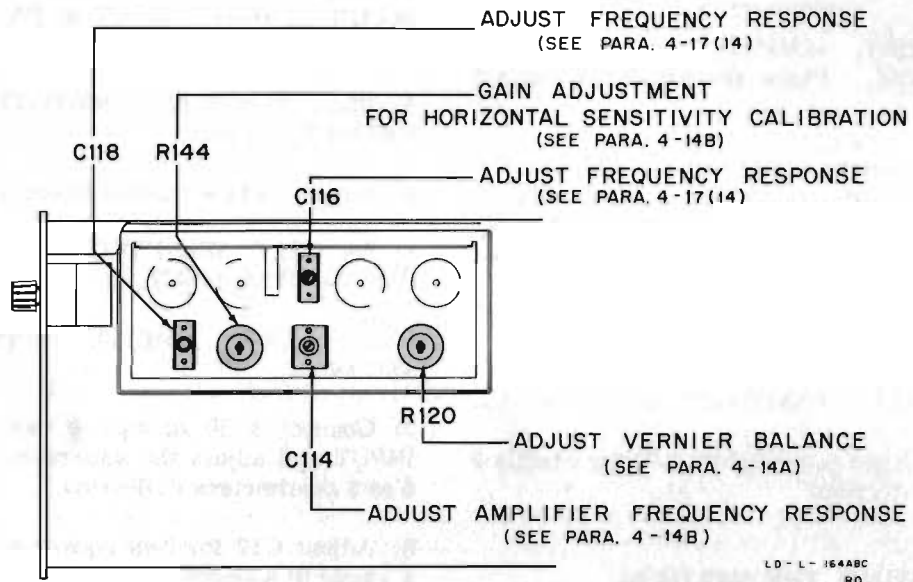

← FRONT PANEL

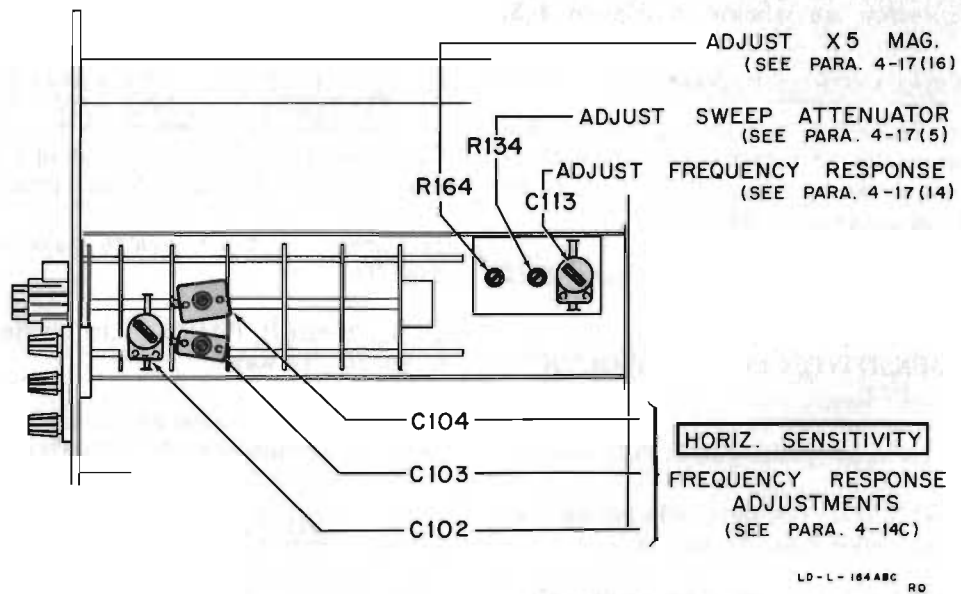

Figure 4-6. Horizontal Amplifier Adjustment Locations

4-14 ADJUSTING HORIZONTAL AMPLIFIER

To adjust the Horizontal Amplifier, refer to Figure 4-6 and proceed as follows:

A. VERNIER BALANCE ADJUSTMENT

To adjust the VERNIER balance allow the instrument to warm up thoroughly and adjust Horizontal balance as shown by Figure 2-3; then refer to Figure 4-6 and:

- 1) Short the INPUT terminals and set the INPUT switch to DC.
- 2) Set the HORIZ. SENSITIVITY to 1 MILLI-VOLT/CM and the VERNIER to CAL.
- 3) Center the spot with the HORIZ. POS. control.
- 4) Turn the VERNIER completely counterclockwise and return the spot to the center with R120, Bal. Adj. The spot will now be stationary as the VERNIER is rotated.

B. AMPLIFIER GAIN AND FREQUENCY RESPONSE ADJUSTMENTS

To adjust the gain and frequency response, refer to Figure 4-6 and proceed as follows:

- 1) Set HORIZ. SENSITIVITY switch to CAL. and the VERNIER to CAL.
- 2) Adjust R144 for exactly 6 centimeters deflection.
- 3) Set VERT. SENSITIVITY to 2 VOLTS/CM.
- 4) Connect an 8 kc (approximately) sine wave to the Vertical INPUT of the oscilloscope and to the SYNC. IN terminal of the 211A square wave generator; adjust the sine wave for 10 cm deflection.
- 5) Set HORIZ. SENSITIVITY to 50 MILLI-VOLTS/CM.
- 6) Connect a 50 kc square wave to the Horizontal INPUT, and adjust the square wave amplitude for 6 to 8 cm deflection.
- 7) Adjust C114 for best square wave response.

NOTE

Some vacuum tubes require more capacity for compensation than the maximum value of C114.

Capacitor C115 may be connected in parallel with C114 to increase the maximum capacity to 1340 μ f, permitting a greater percentage of vacuum tubes to be used.

C. INPUT ATTENUATOR FREQUENCY RESPONSE ADJUSTMENTS

To adjust the frequency response at the input attenuator, refer to Figure 4-6 and proceed as follows:

- 1) Set VERT. SENSITIVITY to 2 VOLTS/CM.
- 2) Connect an 800 cps (approximately) sine wave to the Vertical INPUT of the oscilloscope and to the Sync-In terminal of the 211A square wave generator; adjust the sine wave for 10 centimeter deflection.
- 3) Set HORIZ. SENSITIVITY to 10 VOLTS/CM (VERNIER in CAL.).
- 4) Connect a 5 kc square wave to the Horizontal INPUT and adjust its amplitude for 6 centimeter deflection.
- 5) Make the following adjustments on the ranges indicated for the best square wave response, adjusting the square-wave amplitude to 6 centimeters on each range.

<u>VOLTS/CM</u>	<u>ADJUST</u> (see Fig. 4-6)
10	C102
1	C104
.1	C103

4-15 PHASE SHIFT ADJUST

Phase shift between Vertical and Horizontal Amplifiers.

If the square wave response of the Vertical and Horizontal Amplifier was carefully set, the relative phase shift between the two amplifiers should not exceed one degree at frequencies below 50 kc.

To check Phase Balance:

- 1) Set VERT. and HORIZ. SENSITIVITY to 50 MILLIVOLTS/CM and VERNIER to CAL.
- 2) Apply a 50 kc sine-wave signal to the HORIZ. INPUT and VERT. INPUT. Center pattern and adjust signal amplitude for 6 cm vertical and 6 cm horizontal deflection.

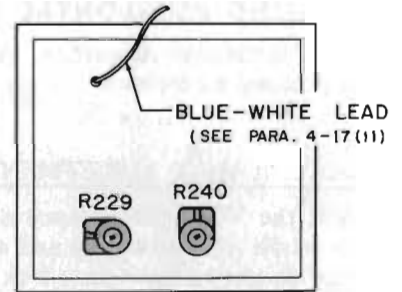
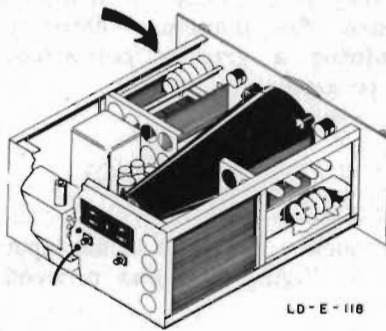

TUBE SIDE OF BOARD (DOOR OPEN)

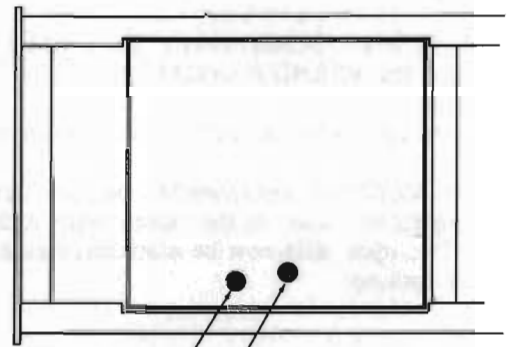
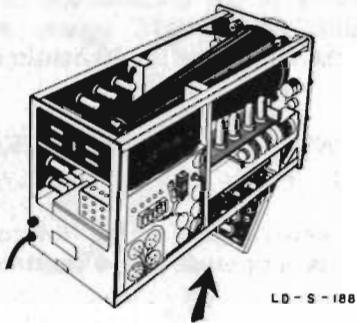

R240
ADJUST CALIBRATOR
(SEE PARA. 4-12)

R229
ADJUST SWEEP LENGTH
(SEE PARA. 4-17(17))

BOTTOM VIEW
(CABINET MODEL)

RIGHT SIDE VIEW
(RACK MOUNT MODEL)

SWEEP TIME /CM ADJUSTMENTS
(SEE PARA. 4-17)

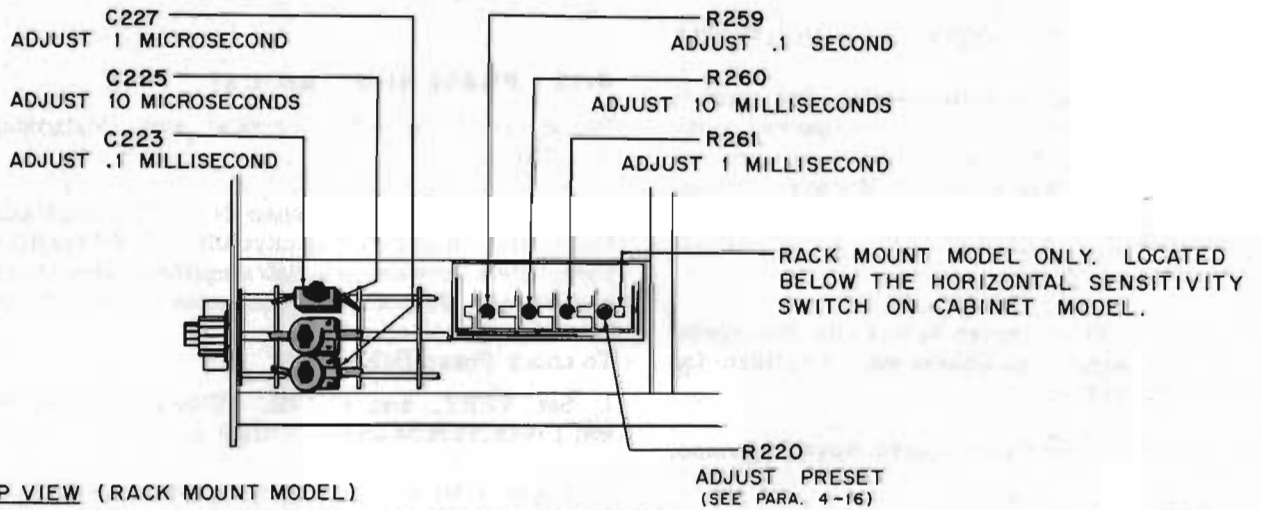

TOP VIEW (RACK MOUNT MODEL)
BOTTOM VIEW (CABINET MODEL WITH SWEEP DECK OPEN)

LD-L-165
RO

Figure 4-7. Sweep Generator Adjustment Locations

The opening of the pattern, if any, should not exceed a tenth of a centimeter. If necessary to correct phase difference, adjust C114 for closure of the pattern (Figure 4-6).

4-16 ADJUSTING PRESET

To adjust Preset refer to Figure 4-7 and proceed as follows:

- 1) Set VERT. SENSITIVITY to OFF, SWEEP TIME/CM switch to .1 MILLISECOND and SWEEP MODE control maximum counterclockwise to PRESET. Set SYNC selector to INT.
- 2) Connect a dc voltmeter between ground (+) and the center tap of R220 the PRESET adjust control.
- 3) Turn R220 fully counterclockwise. Then slowly adjust R220 clockwise until the sweep generator begins to free run. Turn R220 counterclockwise until the sweep just stops and record this voltage which should be about -26 volts.
- 4) Set R220 to give a voltmeter indication exactly 2 volts less negative than the voltage noted.

4-17 ADJUSTING THE SAWTOOTH GENERATOR AND SWEEP AMPLIFIER

To adjust the Sawtooth Generator and Sweep Amplifier refer to Figures 4-6 and 4-7 and proceed as follows:

- 1) Set SYNC to INT., SWEEP MODE to PRESET and TRIGGER LEVEL to "0".
- 2) Set HORIZ. SENSITIVITY to INT. SWEEP X1, SWEEP TIME/CM to 1 MILLISECOND, and its VERNIER to CAL.
- 3) Connect 1 kc (1000 μ sec) time markers to the Vertical INPUT.
- 4) Set R261, 1 Millisecond Adj., on the potentiometer board, to its mechanical center.
- 5) Adjust R134, Sweep Attenuator, (Figure 4-6) and HORIZ. POS. for approximately 1 time marker/cm. This is a rather coarse adjustment. Set it as close as is practical. Then make the final adjustment with R261.
- 6) Set SWEEP TIME/CM to 10 MILLISECONDS and connect 100 cycle (10,000 μ sec) time markers to the Vertical INPUT.

7) Adjust R260 (Figure 4-7) for 1 marker per centimeter.

8) Set SWEEP TIME/CM to .1 SECOND and connect 10 cycle (100,000 μ sec) time markers to the Vertical INPUT.

9) Adjust R259 (Figure 4-7) for 1 marker per centimeter.

10) Disconnect the time mark generator from the Vertical INPUT, set VERT. SENSITIVITY switch to 10 VOLTS/CM, the Vertical and Horizontal input switches to AC, and SWEEP TIME/CM to 5 MICROSECONDS.

11) Disconnect the blue-white lead (Figure 4-7) from the Sweep Generator board and connect it through a 1 microfarad capacitor to the Horizontal INPUT.

12) Connect a wire between V206 pin 1 (6AW8) and the Vertical INPUT.

13) Connect a 50 kc square wave from the 600 ohm output of the ϕ Model 211A to the Horizontal INPUT and adjust its amplitude for about 6 centimeter deflection.

14) Adjust C113 near the HORIZ. SENSITIVITY switch, and C116 and C118 on the Horizontal Amplifier board (Figures 4-6 and 4-7), for best square wave presentation. Remove the wire between V206 pin 1 and the Vertical INPUT.

15) Reconnect the blue-white lead to the Sweep Generator board, and connect the time marker generator to the Vertical INPUT. Make the following adjustment as indicated for 1 time marker per centimeter.

(Fig. 4-7)

<u>Time Marker</u>	<u>SWEEP TIME/CM</u>	<u>Adjust</u>
1 μ sec (1 mc)	1 MICROSEC.	C227
10 μ sec (100 kc)	10 MICROSEC.	C225
.1 msec (10 kc)	.1 MILLISEC.	C223

16) Set HORIZ. SENSITIVITY to INT. SWEEP X5, and adjust R164 (Figure 4-6), for markers 5 centimeters apart.

17) Connect a 500 kc signal to the Horizontal INPUT, set SWEEP TIME/CM to 1 MILLISECOND, set SYNC to EXT, and adjust R229, Sweep Length, (Figure 4-7) for a trace about 10.5 centimeters long.

SCHEMATIC DIAGRAM NOTES

1. Heavy solid line shows main signal path; heavy dashed line shows control, secondary signal, or feedback path.
2. Heavy box indicates front-panel engraving; light box indicates chassis marking.
3. Arrows on potentiometers indicate clockwise rotation as viewed from the round shaft end, counter-clockwise from the rectangular shaft end.
4. Resistance values in ohms, inductance in microhenries, and capacitance in micromicrofarads unless otherwise specified.
5. Rotary switch schematics are electrical representations; for exact switching details refer to the switch assembly drawings.
6. Relays shown in condition prevailing during normal instrument operation.
7. † indicates a selected part. See parts list.
8. Interconnecting parts and assemblies are shown on cable diagram.
9. * indicated value adjusted at factory. Part may be omitted.

VOLTAGE AND RESISTANCE DIAGRAM NOTES

1. Each tube socket terminal is numbered and lettered to indicate the tube element and pin number, as follows:

* = no tube element	P = plate
H = heater	T = target (plate)
K = cathode	R = reflector or repeller
G = control grid	A = anode (plate)
Sc = screen grid	S = spade
Sp = suppressor grid	Sh = shield
Hm = heater mid-tap	NC = no external connection to socket
IS = internal shield	Δ = indefinite reading due to circuit (see 2.)

The numerical subscript to tube-element designators indicates the section of a multiple-section tube; the letter subscript to tube-element designators indicates the functional difference between like elements in the same tube section, such as t for triode and p for pentode.

A socket terminal with an asterisk may be used as a tie point and may have a voltage and resistance shown.

2. Voltages values shown are for guidance; values may vary from those shown due to tube aging or normal differences between instruments. Resistance values may vary considerably from those shown when the circuit contains potentiometers, crystal diodes, or electrolytic capacitors.
3. Voltage measured at the terminal is shown above the line, resistance below the line; measurements made with an electronic multimeter, from terminal to chassis ground unless otherwise noted.
4. A solid line between socket terminals indicates a connection external to the tube between the terminals; a dotted line between terminals indicates a connection inside the tube. Voltage and resistance are given at only one of the two joined terminals.

VERTICAL AMPLIFIER VOLTAGE - RESISTANCE DIAGRAM (VIEWED FROM ETCHED SIDE)

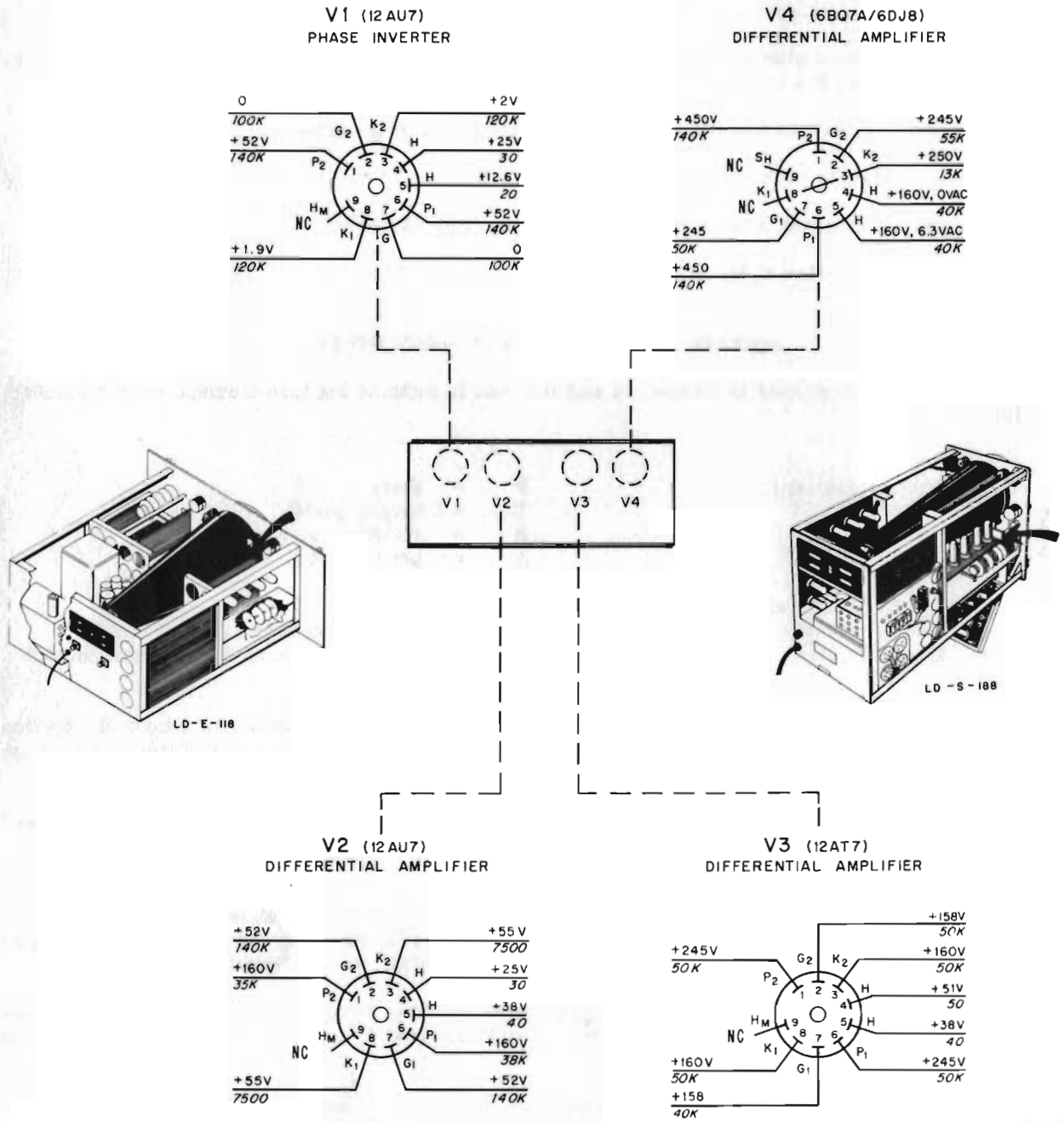
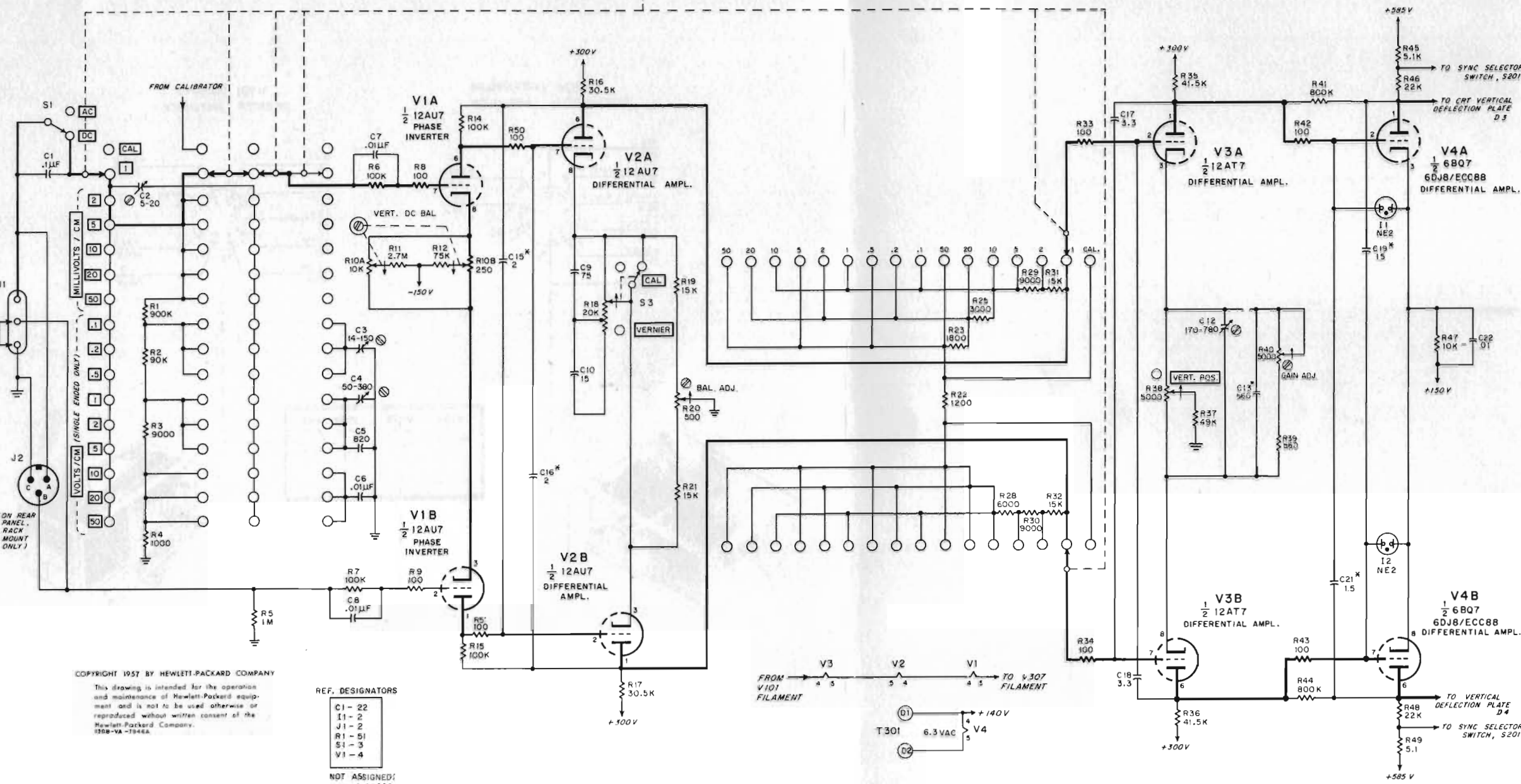

FIGURE 4-8

S2 VERT. SENSITIVITY



COPYRIGHT 1957 BY HEWLETT-PACKARD COMPANY
 This drawing is intended for the operation and maintenance of Hewlett-Packard equipment and is not to be used otherwise or reproduced without written consent of the Hewlett-Packard Company.
 3368-VA-1946A.

- REF. DESIGNATORS
- C1 - 22
 - I1 - 2
 - J1 - 2
 - R1 - 51
 - S1 - 3
 - V1 - 4
- NOT ASSIGNED:
 C11, C14, C20
 R13, R24, R26, R27

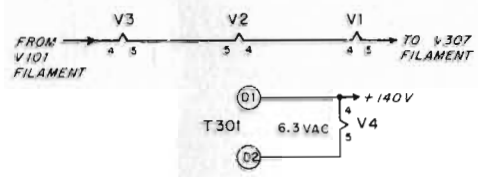

TO VERTICAL DEFLECTION PLATE D4
 TO SYNC SELECTOR SWITCH, S201

HORIZONTAL AMPLIFIER

VOLTAGE-RESISTANCE DIAGRAM

(VIEWED FROM ETCHED SIDE)

V104 (6BQ7/6DJ8)
DIFFERENTIAL AMPLIFIER

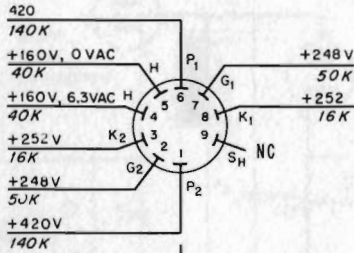

V101 (12AU7)
INVERTER AMPLIFIER

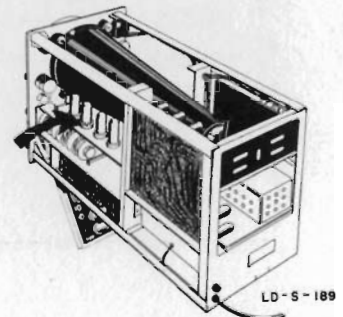
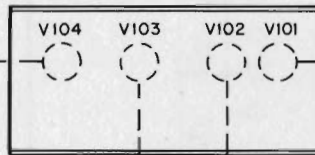
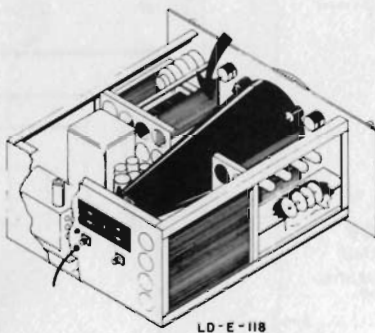
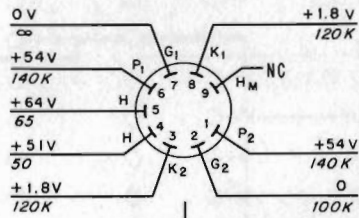

V103 (12AT7)
DIFFERENTIAL AMPLIFIER

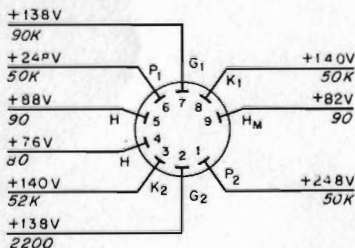

V102 (12AU7)
DIFFERENTIAL AMPLIFIER

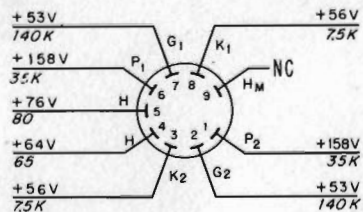
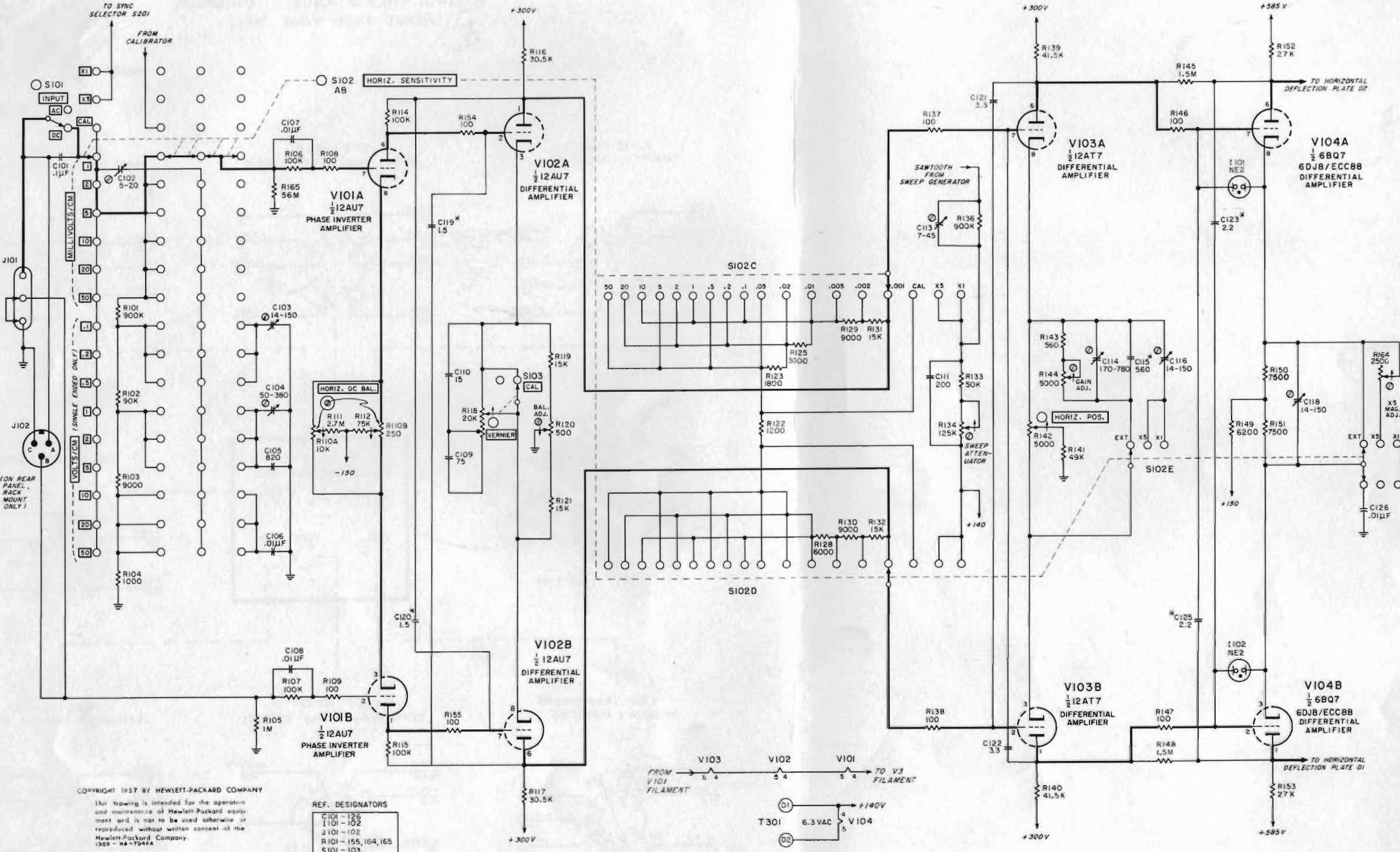

FIGURE 4-10



COPYRIGHT 1957 BY HEWLETT-PACKARD COMPANY

This drawing is intended for the operation and maintenance of Hewlett-Packard equipment and is not to be used otherwise or reproduced without written consent of the Hewlett-Packard Company.
1308 - HA - T9444

REF. DESIGNATORS

C101 - 126
I101 - 102
J101 - 102
R101 - 155, 164, 165
S101 - 103
V101 - 104

NOT ASSIGNED:
C112, C117, C124

R113, R124, R126, R127, R135, R156-163

SWEEP GENERATOR VOLTAGE-RESISTANCE DIAGRAM (VIEWED FROM RIGHT SIDE)

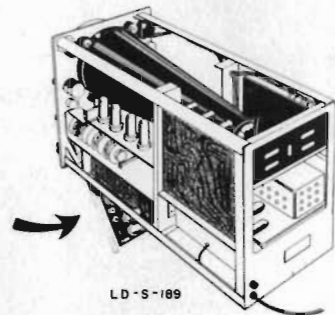

**V202 (12AT7)
TRIGGER GENERATOR**

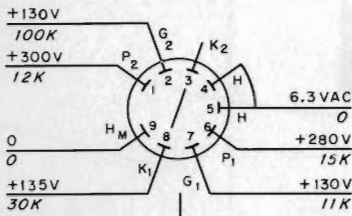

**V203 (6U8)
SWEEP START-STOP TRIGGER**

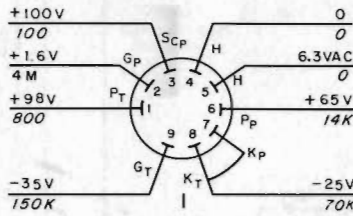

**V204 (6C4)
GATE OUT CATHODE FOLLOWER**

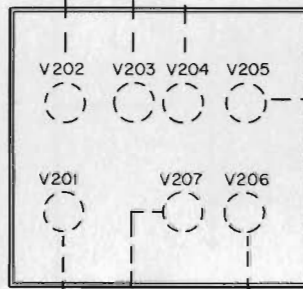
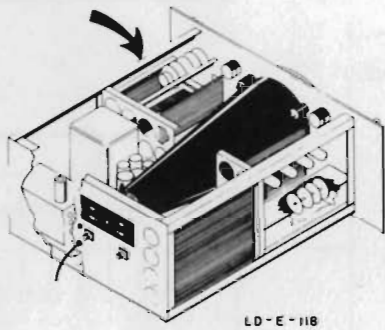
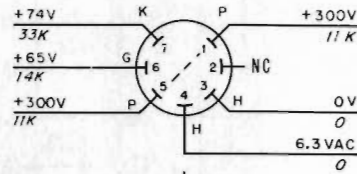

**V205 (12AL5)
INTEGRATOR SWITCH**

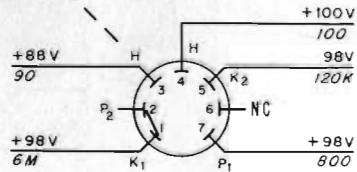

**V201 (6BQ7A/6DJ8)
TRIGGER AMPLIFIER**

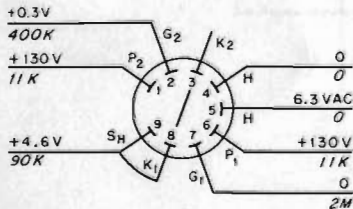

**V207 (12AX7)
RETRIGGERING BIAS CONTROL**

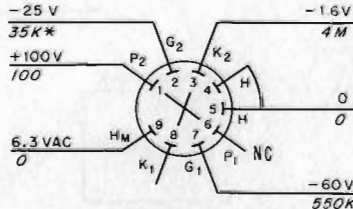

**V206 (6AW8)
INTEGRATOR CATHODE FOLLOWER**

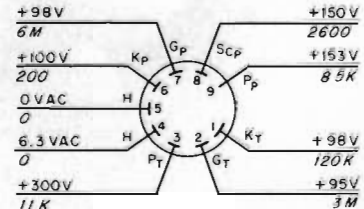
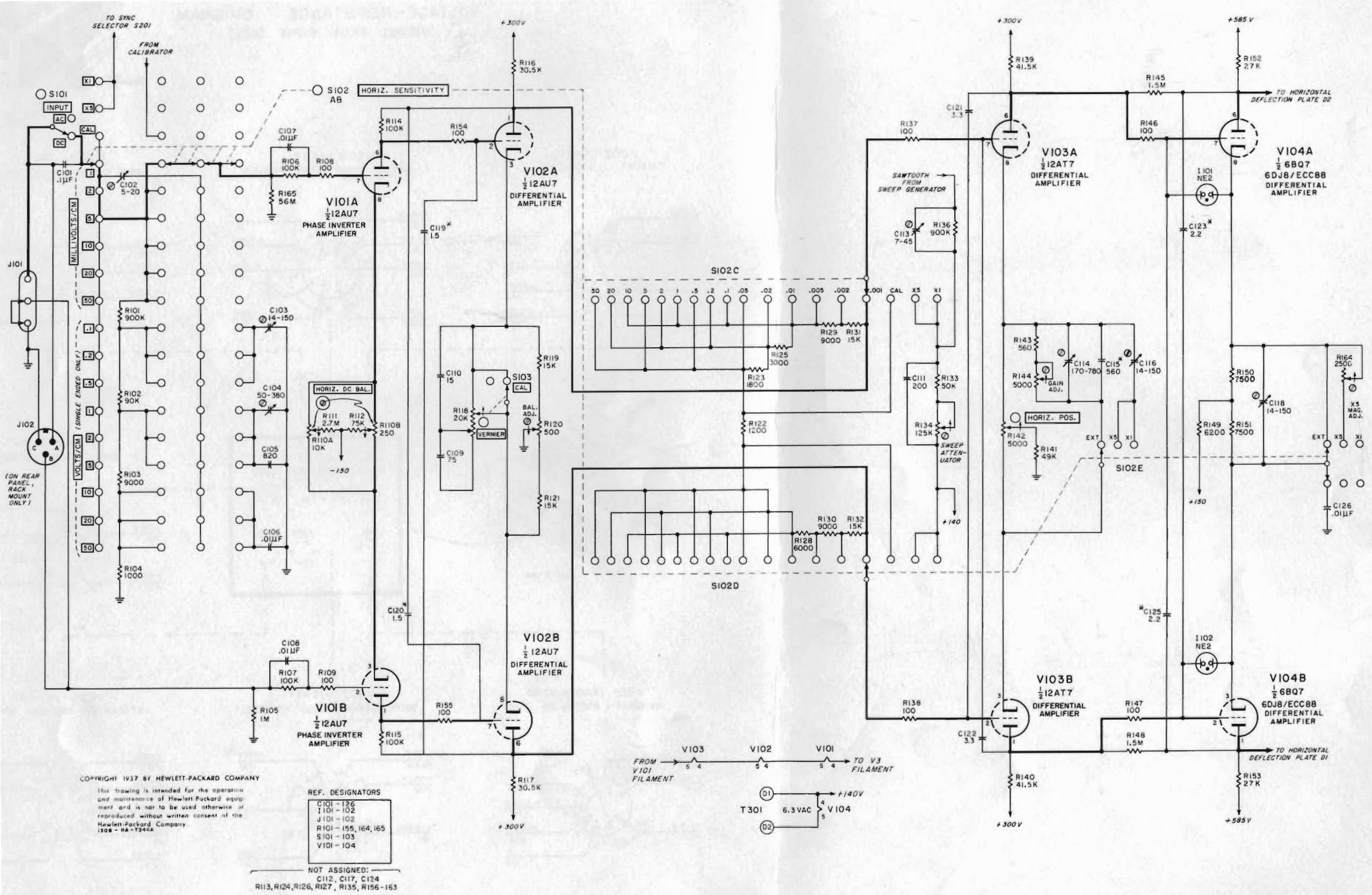

FIGURE 4-12



© COPYRIGHT 1957 BY HEWLETT-PACKARD COMPANY

This drawing is intended for the operation and maintenance of Hewlett-Packard equipment and is not to be used otherwise or reproduced without written consent of the Hewlett-Packard Company.
1508 - HA - T340A

NOTES:

CONDITIONS OF VOLTAGE RESISTANCE MEASUREMENTS:

- a. VOLTAGE -
 VERT. SENSITIVITY = 50 MILLIVOLTS/CM; VERNIER = CAL; INPUT = DC.
 HORIZ. SENSITIVITY = INT. SWEEP XI; VERNIER = CAL; INPUT = DC.
 SWEEP TIME/CM = 50 MILLISECONDS; VERNIER = CAL.
 TRIGGER SLOPE = +; TRIGGER LEVEL = 0; SWEEP MODE = PRESET;
 SYNC = INT.
- b. RESISTANCE -
 SAME AS ABOVE, EXCEPT SYNC = LINE.

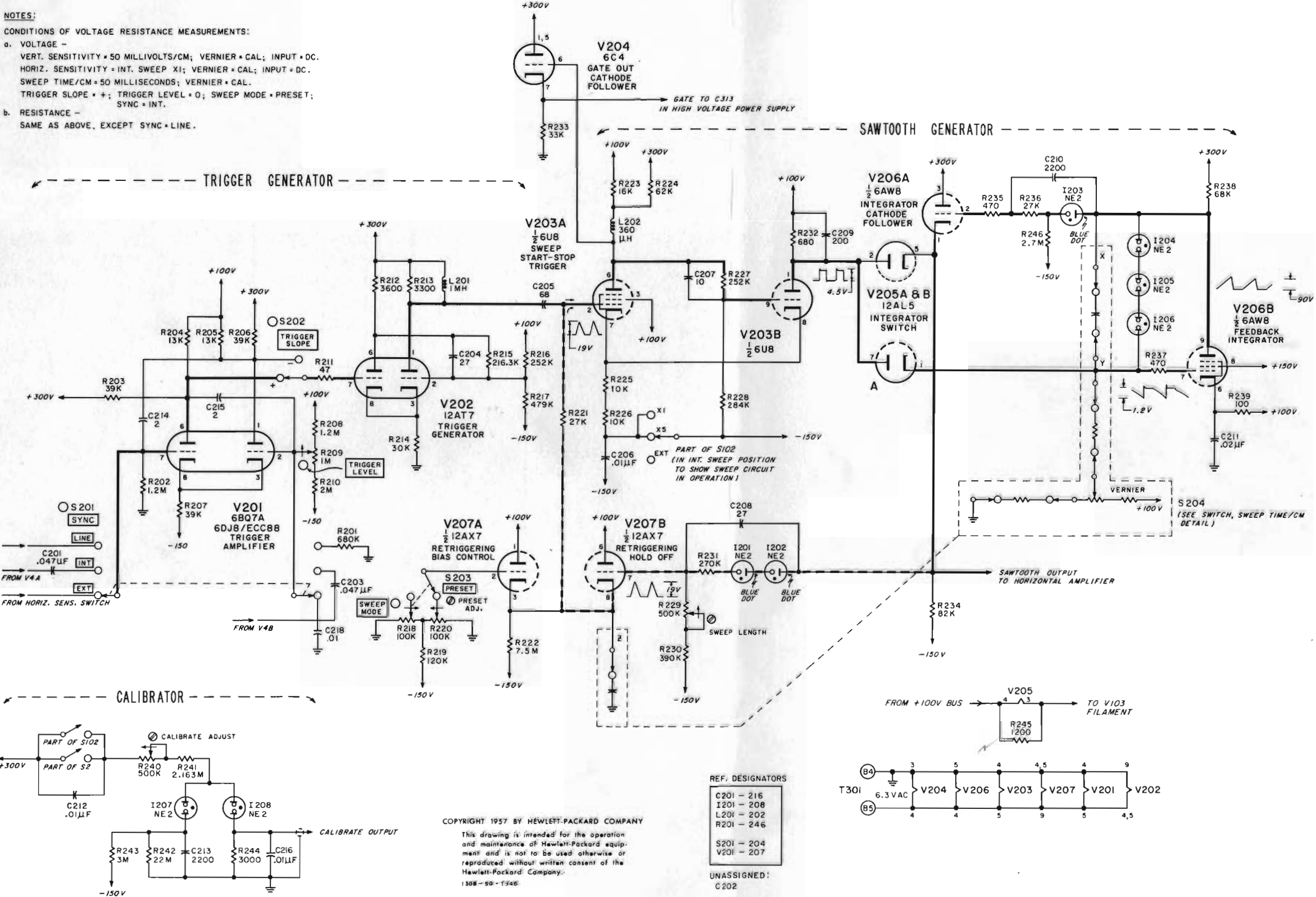

REF. DESIGNATORS

C201 - 216
I201 - 208
L201 - 202
R201 - 246

UNASSIGNED:
 C202

Copyright 1957 by Hewlett-Packard Company.
 This drawing is intended for the operation and maintenance of Hewlett-Packard equipment and is not to be used otherwise or reproduced without written consent of the Hewlett-Packard Company.
 1308-59-1346

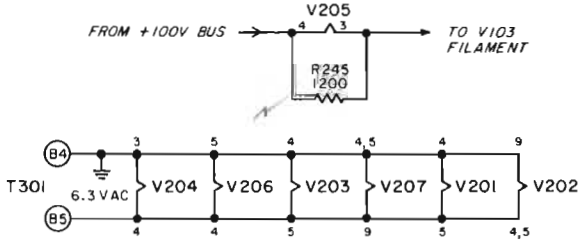

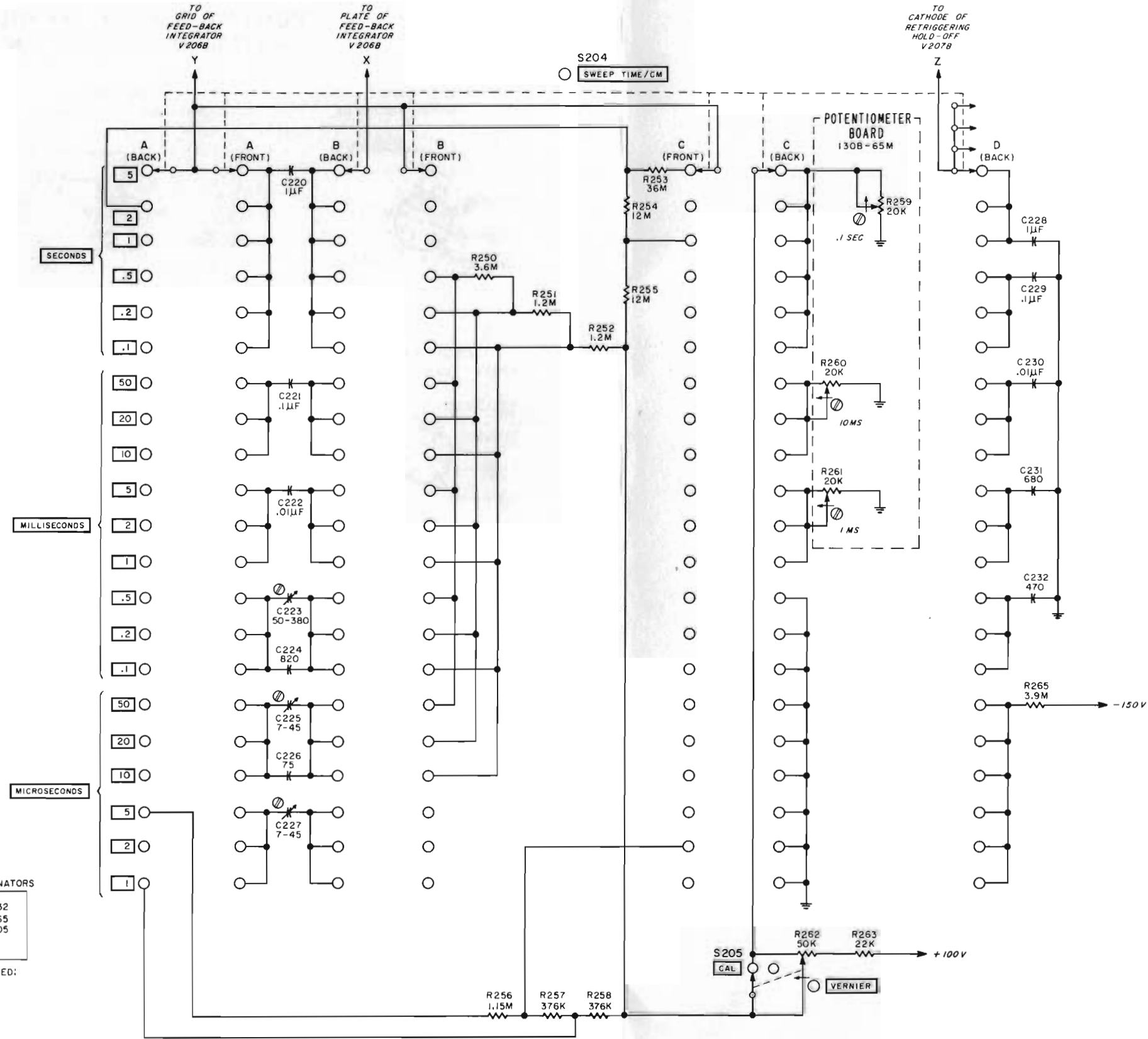

COPYRIGHT 1957 BY HEWLETT-PACKARD COMPANY

This drawing is intended for the operation and maintenance of Hewlett-Packard equipment and is not to be used otherwise or reproduced without written consent of the Hewlett-Packard Company.

This drawing is intended for the operation and maintenance of Hewlett-Packard equipment and is not to be used otherwise or reproduced without written consent of the Hewlett-Packard Company.
1508 - 28 774488

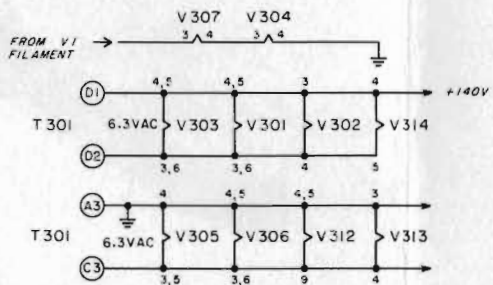
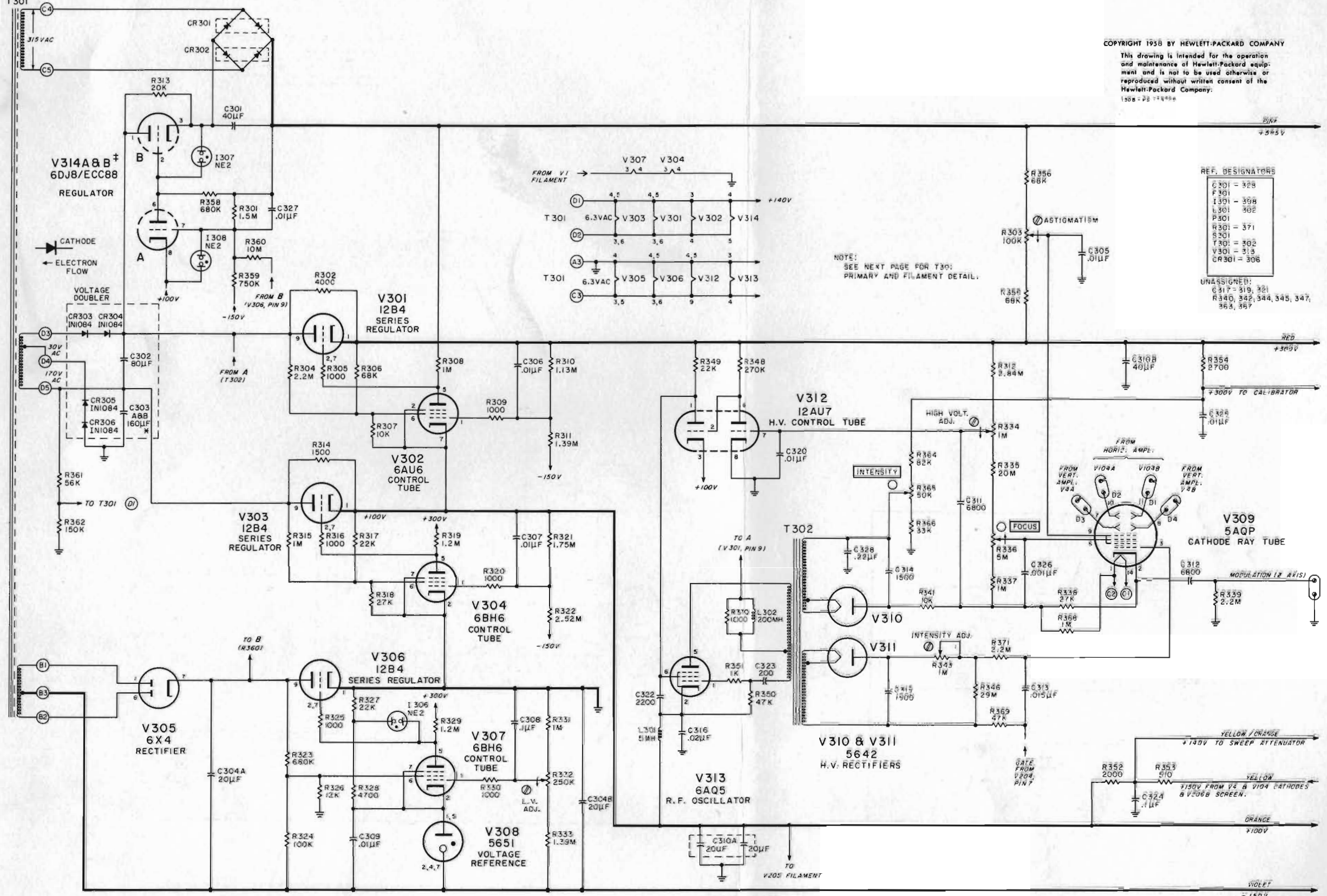

NOTE: SEE NEXT PAGE FOR T301 PRIMARY AND FILAMENT DETAIL.

REF. DESIGNATORS

C301	= 328
F301	= 308
L301	= 302
R301	= 371
S301	= 302
T301	= 313
CR301	= 306

UNASSIGNED:
C317 = 319, 321
R340, 342, 344, 345, 347,
363, 367

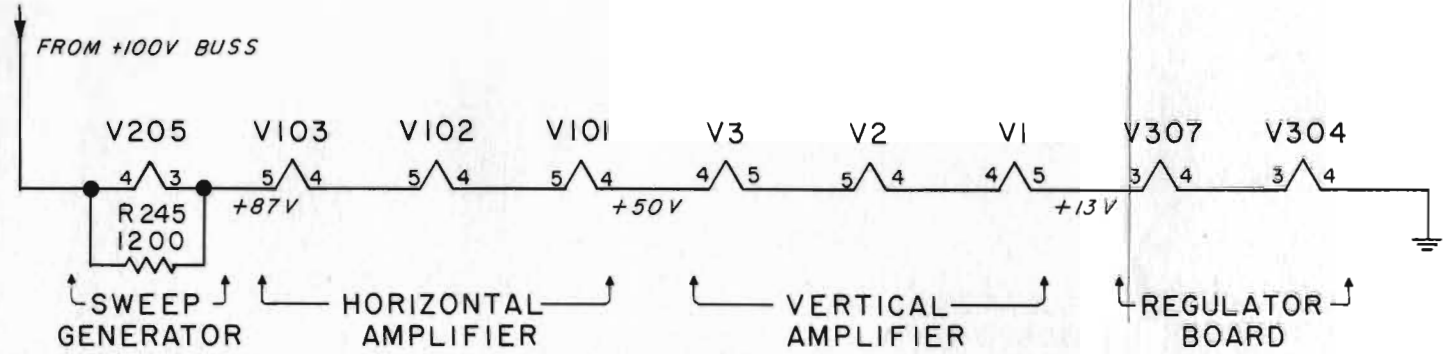

COPYRIGHT 1957 BY HEWLETT-PACKARD COMPANY

This drawing is intended for the operation and maintenance of Hewlett-Packard equipment and is not to be used otherwise or reproduced without written consent of the Hewlett-Packard Company.
T946A

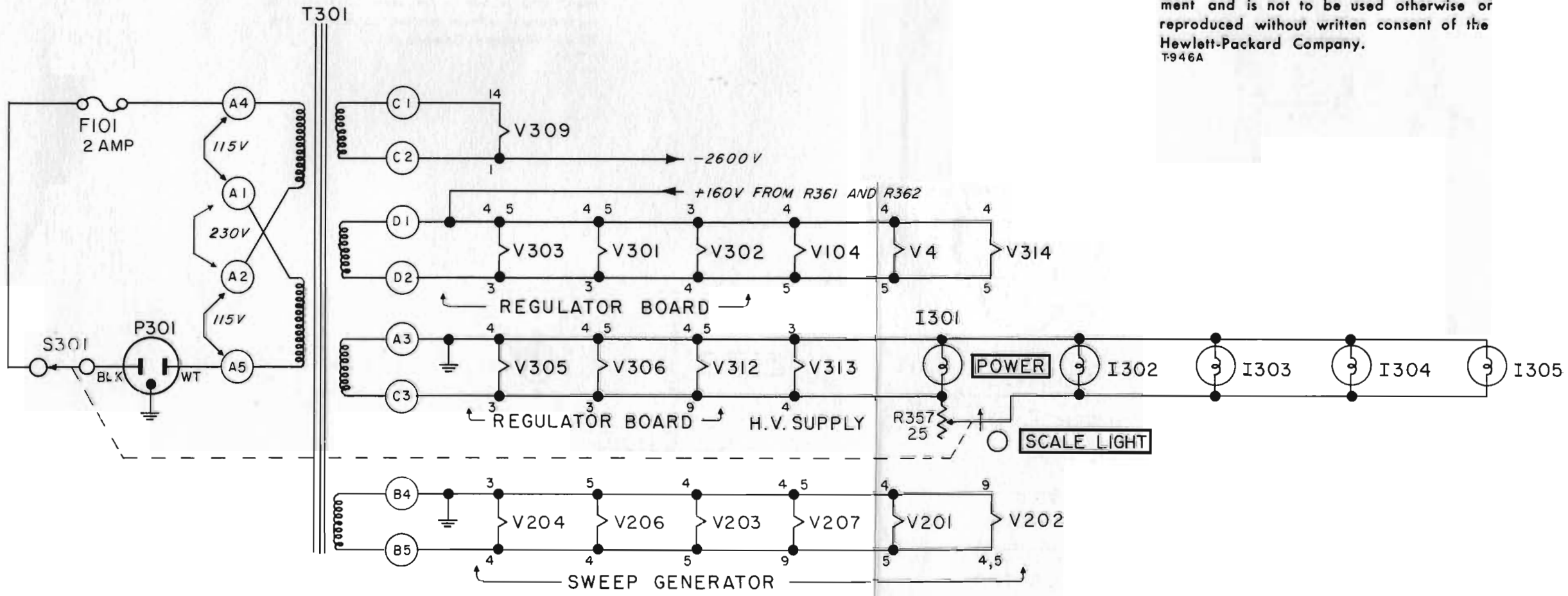

SWEEP TIME / CM SWITCH S204

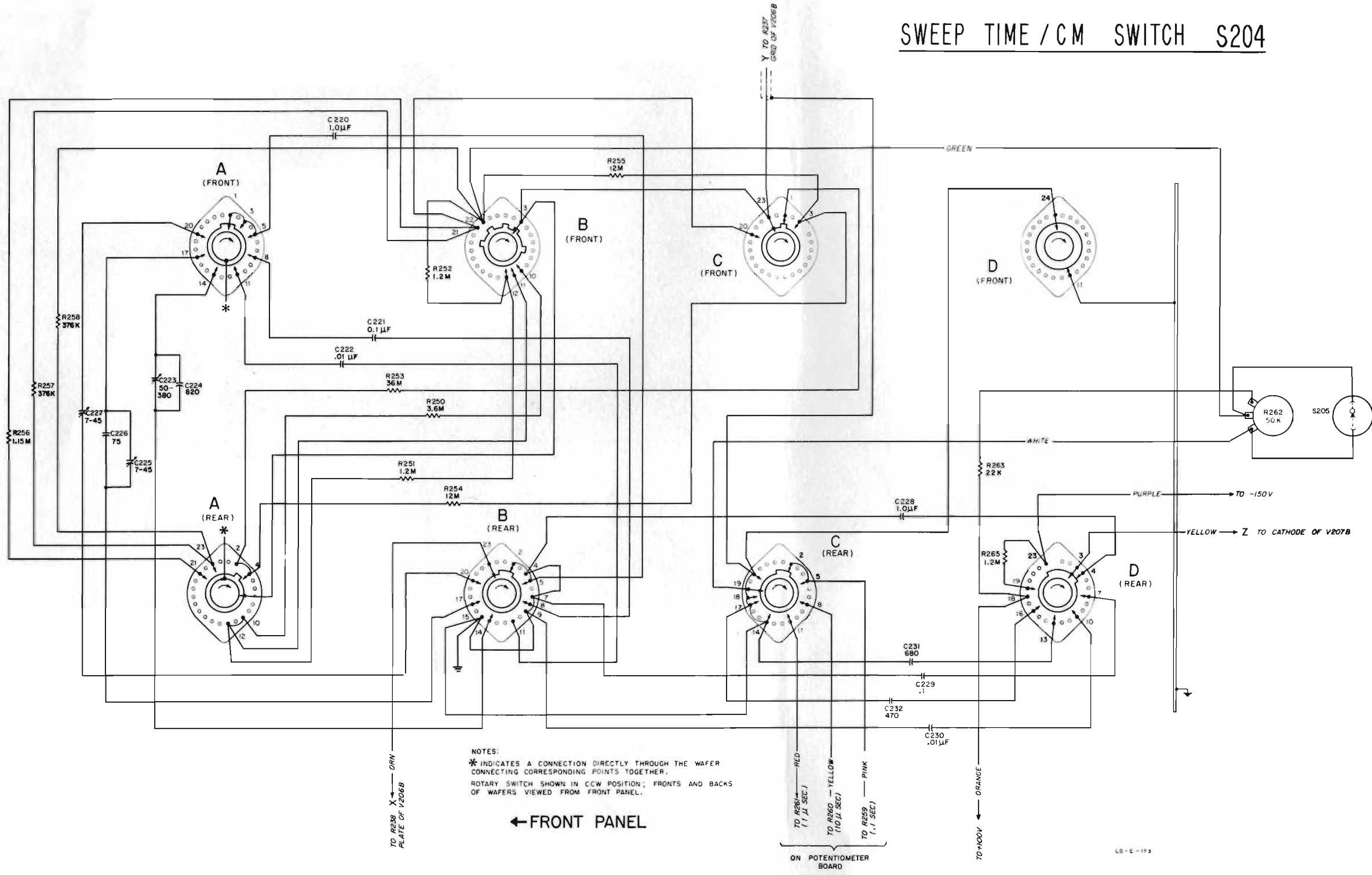

NOTES:
 * INDICATES A CONNECTION DIRECTLY THROUGH THE WAFER CONNECTING CORRESPONDING POINTS TOGETHER.
 ROTARY SWITCH SHOWN IN CCW POSITION; FRONTS AND BACKS OF WAFERS VIEWED FROM FRONT PANEL.

← FRONT PANEL

ON POTENTIOMETER BOARD



CATHODE RAY TUBE WARRANTY

The cathode ray tube supplied in your Hewlett-Packard Oscilloscope and replacement cathode ray tubes purchased from , are guaranteed against electrical failure for one year from the date of sale by the Hewlett-Packard Company. Broken tubes or tubes with burned phosphor are not included in this guarantee.

Your local Hewlett-Packard representative maintains a stock of replacement tubes and will be glad to process your warranty claim for you. Please consult him.

Whenever a tube is returned for a warranty claim, the reverse side of this sheet must be filled out in full and returned with the tube. Follow shipping instructions carefully to insure safe arrival, since no credit can be allowed on broken tubes.

SHIPPING INSTRUCTIONS

- 1) Carefully wrap the tube in 1/4" thick cotton batting or other soft padding material.
- 2) Wrap the above in heavy kraft paper.
- 3) Pack in a rigid container which is at least 4 inches larger than the tube in each dimension.
- 4) Surround the tube with at least four inches of packed excelsior or similar shock absorbing material. Be certain that the packing is tight all around the tube.
- 5) Tubes returned from outside the continental United States should be packed in a wooden box.
- 6) Ship prepaid preferably by AIR FREIGHT or RAILWAY EXPRESS. We do not recommend parcel post or air parcel post shipment.

CRT WARRANTY CLAIM

FROM:

DATE: _____

NAME: _____

COMPANY: _____

ADDRESS: _____

Person to contact for further information:

NAME: _____

TITLE: _____

COMPANY: _____

ADDRESS: _____

To process your claim quickly please enter the information indicated below:

1)  INSTRUMENT MODEL _____ SERIAL _____

2) TUBE TYPE _____ SERIAL _____

3) ORIGINAL TUBE _____ REPLACEMENT TUBE _____

4) YOUR PURCHASE ORDER NO. _____

5) DATE PURCHASED _____

6) PURCHASED FROM _____

7) COMPLAINT: (Please describe nature of trouble) _____

8) OPERATING CONDITIONS: (Please describe conditions prior to and at time of failure) _____

SIGNATURE _____

SECTION V TABLE OF REPLACEABLE PARTS

NOTE

Readily available standard-components have been used in this instrument, whenever possible. However, special components may be obtained from your local Hewlett-Packard representative or from the factory.

When ordering parts always include:

1.  Stock Number.
2. Complete description of part including circuit reference.
3. Model number and serial number of instrument.
4. If part is not listed give complete description, function, and location of part.

If there are any corrections for the Table of Replaceable Parts they will be listed on an Instruction Manual Change sheet at the front of this manual.

TABLE OF REPLACEABLE PARTS

CIRCUIT REF.	DESCRIPTION, MFR. * & MFR. DESIGNATION	(p) STOCK NO.	#			
C1	Capacitor: fixed, mylar, 0.1 μ f \pm 20%, 600 vdcw Texas Capacitor Co.	16-110	2			
C2	Capacitor: variable, ceramic, 5-20 μ f 500 vdcw L*	13-20	2			
C3	Capacitor: variable, mica, 14 - 50 μ f 500 vdcw L*	13-33	4			
C4	Capacitor: variable, mica, 50-380 μ f 175 vdcw QQ*	13-5	2			
C5	Capacitor: fixed, silver mica, 820 μ f \pm 5%, 500 vdcw Z*	15-104	4			
C6	Capacitor: fixed, mica .01 μ f \pm 5%, 300 vdcw Z*	14-24	3			
C7, 8	Capacitor: fixed, ceramic, 10,000 μ f \pm 20%, 1000 vdcw CC*	15-43	6			
C9	Capacitor: fixed, mica, 75 μ f \pm 5%, 300 vdcw V*	14-75	3			
C10	Capacitor: fixed, mica, 15 μ f \pm 10%, 500 vdcw V*	14-15	2			
C11	This circuit reference not assigned					
C12	Capacitor: variable, mica 170-780 μ f 175 vdcw QQ*	13-32	3			
C13	Capacitor: fixed, mica, 560 μ f \pm 10%, 500 vdcw Electrical value adjusted at factory	14-81	2			
C14	This circuit reference not assigned					
C15, 16	Capacitor: fixed, titanium dioxide, 2 μ f \pm 5%, 500 vdcw Electrical value adjusted at factory DD*	15-118	4			
C17, 18	Capacitor: fixed, titanium dioxide, 3.3 μ f \pm 10%, 500 vdcw DD*	15-78	4			
C19	Capacitor: fixed, titanium dioxide, 1.5 μ f \pm 20%, 500 vdcw DD*	15-38	4			
C20	This circuit reference not assigned					

* See "List of Manufacturers Code Letters For Replaceable Parts Table".

Total quantity used in the instrument.

TABLE OF REPLACEABLE PARTS

CIRCUIT REF.	DESCRIPTION, MFR. * & MFR. DESIGNATION	Ⓟ STOCK NO.	#			
C21	Same as C19 Electrical value adjusted at factory					
C22	Same as C7					
C23 thru C100	These circuit references not assigned					
C101	Same as C1					
C102	Same as C2					
C103	Same as C3					
C104	Same as C4					
C105	Same as C5					
C106	Same as C6					
C107, 108	Same as C7					
C109	Same as C9					
C110	Same as C10					
C111	Capacitor: fixed, mica, 200 μ f \pm 10%, 500 vdcw V*	14-200	1			
C112	This circuit reference not assigned					
C113	Capacitor: variable, ceramic, 7-45 μ f, 500 vdcw L*	13-1	3			
C114	Same as C12					
C115	Same as C13					
C116	Same as C3					
C117	This circuit reference not assigned					
C118	Same as C3					
C119, 120	Same as C19 Electrical value adjusted at factory					
C121, 122	Same as C17					

* See "List of Manufacturers Code Letters For Replaceable Parts Table".

Total quantity used in the instrument.

TABLE OF REPLACEABLE PARTS

CIRCUIT REF.	DESCRIPTION, MFR. * & MFR. DESIGNATION	Ⓢ STOCK NO.	#			
C123	Capacitor: fixed, titanium dioxide, 2.2 μf $\pm 10\%$, 500 vdcw Electrical value adjusted at factory DD*	15-52	2			
C124	This circuit reference not assigned					
C125	Same as C123 Electrical value adjusted at factory					
C126	Capacitor: fixed, paper, .01 μf $\pm 10\%$, 600 vdcw CC*	16-11	2			
C127 thru C200	These circuit references not assigned					
C201	Capacitor: fixed, paper, .047 μf $\pm 10\%$, 1000 vdcw CC*	16-114	2			
C202	This circuit reference not assigned					
C203	Same as C201					
C204	Capacitor: fixed, mica, 27 μf $\pm 10\%$, 500 vdcw V*	14-17	2			
C205	Capacitor: fixed, mica, 68 μf $\pm 10\%$, 500 vdcw V*	14-60	1			
C206	Same as C7					
C207	Capacitor: fixed, ceramic, 10 μf $\pm 0.5\%$, 500 vdcw K*	15-30	1			
C208	Same as C204					
C209	Capacitor: fixed, silver mica, 200 μf $\pm 5\%$, 500 vdcw Z*	15-103	1			
C210	Capacitor: fixed, paper, .0022 μf $\pm 10\%$, 600 vdcw CC*	16-22	2			
C211	Capacitor: fixed, ceramic, .02 μf -0% $+100\%$, 600 vdcw G*	15-85	2			
C212	Same as C7					
C213	Same as C210					
C214, 215	Same as C15					

* See "List of Manufacturers Code Letters For Replaceable Parts Table".

Total quantity used in the instrument.

ERRATA:

C218: Add capacitor, fixed, ceramic, .01uf ±20%, 250 vdcw; -hp- Stock No. 15-43, Mfr., CC e 5

TABLE OF REPLACEABLE PARTS

CIRCUIT REF.	DESCRIPTION, MFR. * & MFR. DESIGNATION	Ⓢ STOCK NO.	#			
C216	Capacitor: fixed, ceramic, .01 μf ±20%, 250 vdcw CW*	15-135	1			
C217 thru C219	These circuit references not assigned					
C220	Capacitor: fixed, mylar, 1.0 μf ±5%, 200 vdcw CW*	16-102	2			
C221	Capacitor: fixed, mylar, 0.1 μf ±5%, 200 vdcw CW*	16-103	1			
C222	Capacitor: fixed, mylar, .01 μf ±5%, 400 vdcw CW*	16-101	1			
C223	Same as C4					
C224	Same as C5					
C225	Same as C113					
C226	Same as C9					
C227	Same as C113					
C228	Same as C220					
C229	Capacitor: fixed, paper, 0.1 μf ±10%, 400 vdcw CC*	16 -35	4			
C230	Same as C126					
C231	Capacitor: fixed, mica, 680 μmf ±10%, 500 vdcw Z*	14-21	1			
C232	Capacitor: fixed, mica, 470 μmf ±10%, 500 vdcw V*	14-62	1			
C233 thru C300	These circuit references not assigned					
C301	Capacitor: fixed, electrolytic, 2 section, 20 μf/sect. CC*	18-22HP	2			
C302	Capacitor: fixed, electrolytic, 80 μf, 300 vdcw X*	18-64	1			
C303	Capacitor: fixed, electrolytic, 160 μf, 450 vdcw Electrical value adjusted at factory CC*	18-51HP	1			

* See "List of Manufacturers Code Letters For Replaceable Parts Table".
Total quantity used in the instrument.

TABLE OF REPLACEABLE PARTS

CIRCUIT REF.	DESCRIPTION, MFR. * & MFR. DESIGNATION	Ⓢ STOCK NO.	#			
C304A, B	Same as C301					
C305	Capacitor: fixed, paper, 0.1 μ f \pm 10%, 1000 vdcw J*	16-82	1			
C306, 307	Capacitor: fixed, tubular, .01 μ f \pm 20%, 400 vdcw CC*	16-109	5			
C308	Same as C229					
C309	Same as C306					
C310A, B	Capacitor: fixed, electrolytic, 4 sections, 20 μ f/sect., 450 vdcw CC*	18-42HP	2			
C311, 312	Capacitor: fixed, paper, .0068 μ f \pm 10%, 5000 vdcw CC*	16-93	3			
C313	Capacitor: fixed, paper, .015 μ f \pm 10%, 3000 vdcw CC*	16-126	1			
C314, 315	Capacitor: fixed, paper, .0015 μ f \pm 20%, 500 vdcw CC*	16-125	2			
C316	Capacitor: fixed, ceramic, .02 μ f -0% +100%, 600 vdcw Radio Mat. Co.	15-85	1			
C317 thru C319	These circuit references not assigned					
C320	Same as C306					
C321	This circuit reference not assigned					
C322	Capacitor: fixed, ceramic, 2000 μ f \pm 20%, 1000 vdcw L*	15-80	2			
C323	Capacitor: fixed, mica, 200 μ f \pm 10%, 500 vdcw V*	14-200	1			
C324	Same as C229					
C325	Same as C306					
C326	Capacitor: fixed, paper, .001 μ f \pm 10%, 600 vdcw CC*	16-21	1			
C327	Same as C7					
C328	Capacitor: fixed, paper, .22 μ f 400 vdcw CC*	16-48	1			

* See "List of Manufacturers Code Letters For Replaceable Parts Table".

Total quantity used in the instrument.

TABLE OF REPLACEABLE PARTS

CIRCUIT REF.	DESCRIPTION, MFR. * & MFR. DESIGNATION	Ⓢ STOCK NO.	#			
CR301, 302	Rectifier, selenium CN*	212-114	2			
CR303 thru CR306	Rectifier, silicon: 500 V PIV BV*	212-147	4			
F301	Fuse, cartridge: 2 amp, slow blow for 115 V 1/2 amp, slow blow, for 230 V operation T*	211-16 211-20	1 1			
I1, 2	Lamp, glow: 1/25 W, 90 vdcw, 65 VAC, NE2 O*	211-43	6			
I3 thru I100	These circuit references not assigned					
I101, 102	Same as I1					
I103 thru I301	These circuit references not assigned					
I302 thru I305	Lamp, incandescent: 6-8V, .15 amp O*	211-47	4			
I306	This circuit reference not assigned					
I307, 308	Same as I1					
J1	Binding Post Assembly: red HP*	AC-10D	4			
	Insulator, binding post (rack model) HP*	AC-54A	4			
	Insulator, binding post (cabinet model) HP*	AC-54B	2			
	Connector Assembly HP*	G-76J	1			
J2	Connector, receptacle: male, 3 contact (on rear panel, rack mount only) CU*	125-58	2			
J3 thru J100	These circuit references not assigned					

* See "List of Manufacturers Code Letters For Replaceable Parts Table".

Total quantity used in the instrument.

TABLE OF REPLACEABLE PARTS

CIRCUIT REF.	DESCRIPTION, MFR. * & MFR. DESIGNATION	Ⓢ STOCK NO.	#			
J101	Binding Post Assembly: red	HP* AC-10D	(2)	See	J1	
	Insulator, binding post (rack model)	HP* AC-54A	(2)	See	J1	
	Insulator, binding post (cabinet model)	HP* AC-54B	(1)	See	J1	
	Connector Assembly	HP* G-76K	1			
J102	Same as J2					
L201	Coil, choke: 1 μ h \pm 10%	CG* 48-96	1			
L202	Coil, r. f.: 360 μ h	CG* 48-63	1			
L203 thru L300	These circuit references not assigned					
L301	Coil, r. f.: 5 μ h	CG* 48-61	1			
L302	Coil, r. f.: 200 μ h	CG* 48-34	1			
P1	Cord, power	Cornish Wire Co. 812-106	1			
R1	Resistor: fixed, deposited carbon, 900,000 ohms \pm 1%, 1 W	NN* 33-900K	2			
R2	Resistor: fixed, deposited carbon, 90,000 ohms \pm 1%, 1/2 W	NN* 33-90K	2			
R3	Resistor: fixed, deposited carbon, 9000 ohms \pm 1%, 1/2 W	NN* 33-9000	1			
R4	Resistor: fixed, deposited carbon, 1000 ohms \pm 1%, 1/2 W	NN* 33-1000	2			
R5	Resistor: fixed, deposited carbon, 1 megohm \pm 1%, 1/2 W	NN* 33-1M	4			
R6, 7	Resistor: fixed, composition, 100,000 ohms \pm 10%, 1/2 W	B* 23-100K	4			
R8, 9	Resistor: fixed, composition, 100 ohms \pm 10%, 1/2 W	B* 23-100	17			

* See "List of Manufacturers Code Letters For Replaceable Parts Table".

Total quantity used in the instrument.

TABLE OF REPLACEABLE PARTS

CIRCUIT REF.	DESCRIPTION, MFR. * & MFR. DESIGNATION	Ⓢ STOCK NO.	#			
R10A, B	Resistor: variable, dual concentric, linear taper, Rear section: 250 ohms $\pm 10\%$ Front section: 10,000 ohms $\pm 10\%$, 2 W BO*	210-199	2			
R11	Resistor: fixed, composition, 2.7 megohms $\pm 10\%$, 1/2 W B*	23-2.7M	3			
R12	Resistor: fixed, deposited carbon, 75,000 ohms $\pm 1\%$, 1 W NN*	31-75K	2			
R13	This circuit reference not assigned					
R14, 15	Resistor: fixed, metal film, 100,000 ohms $\pm 1\%$, 1/2 W The Daven Co.	330-100K	4			
R16, 17	Resistor: fixed, deposited carbon, 30,500 ohms $\pm 1\%$, 1 W NN*	31-30.5K	4			
R18	Resistor: variable, composition, 20,000 ohms Part of S3 BO*	210-195	1			
R19	Resistor: fixed, deposited carbon, 15,000 ohms $\pm 1\%$, 1/2 W NN*	33-15K	8			
R20	Resistor: variable, linear taper, 500 ohms $\pm 20\%$, 2/10 W BO*	210-203	2			
R21	Same as R19					
R22	Resistor: fixed, deposited carbon, 1200 ohms $\pm 1\%$, 1/2 W NN*	33-1200	2			
R23	Resistor: fixed, deposited carbon, 1800 ohms $\pm 1\%$, 1/2 W NN*	33-1800	2			
R24	This circuit reference not assigned					
R25	Resistor: fixed, deposited carbon, 3000 ohms $\pm 1\%$, 1/2 W NN*	33-3000	3			
R26, 27	These circuit references not assigned					
R28	Resistor: fixed, deposited carbon, 6000 ohms $\pm 1\%$, 1/2 W NN*	33-6000	2			
R29, 30	Same as R3					
R31, 32	Same as R19					

* See "List of Manufacturers Code Letters For Replaceable Parts Table".

Total quantity used in the instrument.

TABLE OF REPLACEABLE PARTS

CIRCUIT REF.	DESCRIPTION, MFR. * & MFR. DESIGNATION	Ⓢ STOCK NO.	#			
R33, 34	Same as R8					
R35, 36	Resistor: fixed, deposited carbon, 41,500 ohms $\pm 1\%$, 1 W	NN*	31-41.5K	4		
R37	Resistor: fixed, deposited carbon, 49,000 ohms $\pm 1\%$, 1 W	NN*	31-49K	2		
R38	Resistor: variable, composition, linear taper, 5000 ohms	G*	210-15	2		
R39	Resistor: fixed, composition, 560 ohms $\pm 10\%$, 1/2 W	B*	23-560	2		
R40	Resistor: variable, composition, 5000 ohms $\pm 30\%$, 1/3 W, linear taper	BO*	210-134	2		
R41	Resistor: fixed, deposited carbon, 800,000 ohms $\pm 1\%$, 1/2 W	NN*	33-800K	2		
R42, 43	Same as R8					
R44	Same as R41					
R45	Resistor: fixed, composition, 5100 ohms $\pm 5\%$, 1 W	B*	24-5100-5	1		
R46	Resistor: fixed, composition, 22,000 ohms $\pm 10\%$, 2 W	B*	25-22K	2		
R47	Resistor: fixed, composition, 10,000 ohms $\pm 10\%$, 2 W	B*	25-10K	6		
R48	Same as R46					
R49	Same as R45					
R50, 51	Same as R8					
R52 thru R100	These circuit references not assigned					
R101	Same as R1					
R102	Same as R2					
R103	Resistor: fixed, deposited carbon, 9000 ohms $\pm 1\%$, 1/2 W	NN*	33-9000	3		

* See "List of Manufacturers Code Letters For Replaceable Parts Table".

Total quantity used in the instrument.

TABLE OF REPLACEABLE PARTS

CIRCUIT REF.	DESCRIPTION, MFR. * & MFR. DESIGNATION	Ⓢ STOCK NO.	#			
R104	Same as R4					
R105	Same as R5					
R106, 107	Same as R6					
R108, 109	Same as R8					
R110A, B	Same as R10					
R111	Same as R11					
R112	Same as R12					
R113	This circuit reference not assigned					
R114, 115	Same as R14					
R116, 117	Same as R16					
R118	Resistor: variable, composition, 20,000 ohms	BO* 210-195	1			
R119	Same as R19					
R120	Same as R20					
R121	Same as R19					
R122	Same as R22					
R123	Same as R23					
R124	This circuit reference not assigned					
R125	Same as R25					
R126, 127	These circuit references not assigned					
R128	Same as R28					
R129, 130	Same as R103					
R131, 132	Same as R19					
R133	Resistor: fixed, deposited carbon, 50,000 ohms ±1%, 1/2 W	NN* 33-50K	1			
R134	Resistor: variable, linear taper, 125,000 ohms	BO* 210-110	1			

* See "List of Manufacturers Code Letters For Replaceable Parts Table".
 # Total quantity used in the instrument.

TABLE OF REPLACEABLE PARTS

CIRCUIT REF.	DESCRIPTION, MFR. * & MFR. DESIGNATION	Ⓢ STOCK NO.	#			
R135	This circuit reference not assigned					
R136	Resistor: fixed, deposited carbon, 900,000 ohms $\pm 1\%$, 1/2 W	NN*	33-900K	1		
R137, 138	Same as R8					
R139, 140	Same as R35					
R141	Same as R37					
R142	Same as R38					
R143	Same as R39					
R144	Same as R40					
R145	Resistor: fixed, deposited carbon, 1.5 megohms $\pm 1\%$, 1/2 W	NN*	33-1.5M	3		
R146, 147	Same as R8					
R148	Same as R145					
R149	Resistor: fixed, composition, 6200 ohms $\pm 5\%$, 2 W	B*	25-6.2K-5	1		
R150, 151	Resistor: fixed, composition, 7500 ohms $\pm 5\%$, 1 W	B*	24-7.5K-5	2		
R152, 153	Resistor: fixed, composition, 27,000 ohms $\pm 10\%$, 2 W	B*	25-27K	2		
R154, 155	Same as R8					
R156 thru R163	These circuit references not assigned					
R164	Resistor: variable, composition, 2500 ohms $\pm 20\%$, 1/2 W	G*	210-98	1		
R165	Resistor: fixed, composition, 56 megohms $\pm 10\%$, 1/2 W	B*	23-56M	1		
R166 thru R200	These circuit references not assigned					

* See "List of Manufacturers Code Letters For Replaceable Parts Table".

Total quantity used in the instrument.

TABLE OF REPLACEABLE PARTS

CIRCUIT REF.	DESCRIPTION, MFR. * & MFR. DESIGNATION	Ⓢ STOCK NO.	#			
R201	Resistor: fixed, composition, 680,000 ohms $\pm 10\%$, 1/2 W B*	23-680K	1			
R202	Resistor: fixed, composition, 1.2 megohms $\pm 10\%$, 1/2 W B*	23-1.2M	2			
R203	Resistor: fixed, composition, 39,000 ohms $\pm 5\%$, 2 W B*	25-39K-5	3			
R204, 205	Resistor: fixed, composition, 13,000 ohms $\pm 5\%$, 1 W B*	24-13K-5	2			
R206, 207	Same as R203					
R208	Same as R202					
R209	Part of S202: not separately replaceable					
R210	Resistor: fixed, deposited carbon, 2 megohms $\pm 1\%$, 1/2 W NN*	33-2M	1			
R211	Resistor: fixed, composition, 47 ohms $\pm 10\%$, 1/2 W B*	23-47	1			
R212	Resistor: fixed, composition, 3600 ohms $\pm 5\%$, 1/2 W B*	23-3600-5	1			
R213	Resistor: fixed, composition, 3300 ohms $\pm 10\%$, 1/2 W B*	23-3300	1			
R214	Resistor: fixed, composition, 30,000 ohms $\pm 5\%$, 2 W B*	25-30K-5	1			
R215	Resistor: fixed, deposited carbon, 216,300 ohms $\pm 1\%$, 1/2 W NN*	33-216.3K	1			
R216	Resistor: fixed, deposited carbon, 252,000 ohms $\pm 1\%$, 1/2 W NN*	33-252K	2			
R217	Resistor: fixed, deposited carbon, 479,000 ohms $\pm 1\%$, 1 W NN*	31-479K	1			
R218	Part of S201: not separately replaceable					
R219	Resistor: fixed, composition, 120,000 ohms $\pm 10\%$, 1/2 W B*	23-120K	1			
R220	Resistor: variable, composition, 100,000 ohms $\pm 30\%$, 1/4 W BO*	210-138	2			

* See "List of Manufacturers Code Letters For Replaceable Parts Table".

Total quantity used in the instrument.

R232: Change to resistor, fixed, composition, 1000 ohms
 ±5%, ½ W; -hp- Stock No. 23-1000-5, Mfr., B

TABLE OF REPLACEABLE PARTS

CIRCUIT REF.	DESCRIPTION, MFR. * & MFR. DESIGNATION	Ⓢ STOCK NO.	#			
R221	Resistor: fixed, composition, 27,000 ohms ±10%, 1/2 W B*	23-27K	3			
R222	Resistor: fixed, composition, 7.5 megohms ±5%, 1/2 W B*	23-7.5M-5	1			
R223	Resistor: fixed, composition, 16,000 ohms ±5%, 1 W B*	24-16K-5	1			
R224	Resistor: fixed, composition, 62,000 ohms ±5%, 2 W B*	25-62K-5	1			
R225, 226	Same as R47					
R227	Same as R216					
R228	Resistor: fixed, deposited carbon, 284,000 ohms ±1%, 1/2 W NN*	33-284K	1			
R229	Resistor: variable, composition, linear taper 500,000 ohms ±30%, 1/4 W BO*	210-146	2			
R230	Resistor: fixed, composition, 390,000 ohms ±10%, 1/2 W B*	23-390K	1			
R231	Resistor: fixed, composition, 270,000 ohms ±10%, 1/2 W B*	23-270K	1			
R232	Resistor: fixed, deposited carbon, 680 ohms ±1%, 1/2 W NN*	33-680	1			
R233	Resistor: fixed, composition, 33,000 ohms ±10%, 1 W B*	24-33K	1			
R234	Resistor: fixed, composition, 82,000 ohms ±10%, 2 W B*	25-82K	1			
R235	Resistor: fixed, composition, 470 ohms ±10%, 1/2 W B*	23-470	2			
R236	Same as R221					
R237	Same as R235					
R238	Resistor: fixed, composition, 68,000 ohms ±10%, 2 W B*	25-68K	1			
R239	Same as R8					
R240	Same as R229					

* See "List of Manufacturers Code Letters For Replaceable Parts Table".

Total quantity used in the instrument.

TABLE OF REPLACEABLE PARTS

CIRCUIT REF.	DESCRIPTION, MFR. * & MFR. DESIGNATION	STOCK NO.	#			
R241	Resistor: fixed, deposited carbon, 2.163 megohms $\pm 1\%$, 1 W NN*	31-2.163M	1			
R242	Resistor: fixed, composition, 22 megohms $\pm 10\%$, 1/2 W B*	23-22M	1			
R243	Resistor: fixed, composition, 3 megohms $\pm 5\%$, 1/2 W B*	23-3M-5	1			
R244	Same as R25					
R245	Resistor: fixed, composition, 1200 ohms $\pm 10\%$, 1/2 W B*	23-1200	1			
R246	Same as R11					
R247 thru R249	These circuit references not assigned					
R250	Resistor: fixed, deposited carbon, 3.6 megohms $\pm 1\%$, 1/2 W NN*	33-3.6M	1			
R251, 252	Resistor: fixed, deposited carbon, 1.2 megohms $\pm 1\%$, 1/2 W NN*	33-1.2M	1			
R253	Resistor: fixed, deposited carbon, 36 megohms $\pm 1\%$, 2 W NN*	32-36M	1			
R254, 255	Resistor: fixed, deposited carbon, 12 megohms $\pm 1\%$, 1 W NN*	31-12M	2			
R256	Resistor: fixed, deposited carbon, 1.15 megohms $\pm 1\%$, 1/2 W NN*	33-1.15M	1			
R257, 258	Resistor: fixed, deposited carbon, 376,000 ohms $\pm 1\%$, 1/2 W NN*	33-376K	2			
R259 thru R261	Resistor: variable, composition, 20,000 ohms $\pm 20\%$, 1/4 W BO*	210-136	3			
R262	Resistor: variable, composition, linear taper, 50,000 ohms $\pm 30\%$, 1/3 W BO*	210-153	1			
R263	Resistor: fixed, composition, 22,000 ohms $\pm 10\%$, 1/2 W B*	23-22K	2			
R264	This circuit reference not assigned					

* See "List of Manufacturers Code Letters For Replaceable Parts Table".

Total quantity used in the instrument.

TABLE OF REPLACEABLE PARTS

CIRCUIT REF.	DESCRIPTION, MFR. * & MFR. DESIGNATION	(hp) STOCK NO.	#			
R265	Resistor: fixed, composition, 3.9 megohms $\pm 10\%$, 1/2 W	B* 23-3.9M	1			
R266 thru R300	These circuit references not assigned					
R301	Same as R145					
R302	Resistor: fixed, wirewound, 4000 ohms $\pm 5\%$, 20 W	S* 27-7	1			
R303	Same as R220					
R304	Resistor: fixed, composition, 2.2 megohms $\pm 10\%$, 1 W	B* 24-2.2M	2			
R305	Resistor: fixed, composition, 1000 ohms $\pm 10\%$, 1/2 W	B* 23-1000	6			
R306	Resistor: fixed, composition, 68,000 ohms $\pm 10\%$, 1 W	B* 24-68K	1			
R307	Resistor: fixed, composition, 10,000 ohms $\pm 10\%$, 1/2 W	B* 23-10K	2			
R308	Resistor: fixed, composition, 1 megohm $\pm 10\%$, 1 W	B* 24-1M	2			
R309	Same as R305					
R310	Resistor: fixed, deposited carbon, 1.13 megohms $\pm 1\%$, 1/2 W	NN* 33-1.13M	1			
R311	Resistor: fixed, deposited carbon, 1.39 megohms $\pm 1\%$, 1/2 W	NN* 33-1.39M	2			
R312	Resistor: fixed, deposited carbon, 2.84 megohms $\pm 1\%$, 1 W	NN* 31-2.84M	1			
R313	Resistor: fixed, wirewound, 20,000 ohms $\pm 10\%$, 10 W	S* 26-77	1			
R314	Resistor: fixed, wirewound, 1500 ohms $\pm 10\%$, 20 W	S* 27-46	1			
R315	Same as R308					
R316	Same as R305					

* See "List of Manufacturers Code Letters For Replaceable Parts Table".

Total quantity used in the instrument.

TABLE OF REPLACEABLE PARTS

CIRCUIT REF.	DESCRIPTION, MFR. * & MFR. DESIGNATION	Ⓢ STOCK NO.	#			
R317	Resistor: fixed, composition, 22,000 ohms $\pm 10\%$, 1 W B*	24-22K	1			
R318	Same as R221					
R319	Resistor: fixed, composition, 1.2 megohms $\pm 10\%$, 1 W B*	24-1.2M	2			
R320	Same as R305					
R321	Resistor: fixed, deposited carbon, 1.75 megohms $\pm 1\%$, 1/2 W NN*	33-1.75M	1			
R322	Resistor: fixed, deposited carbon, 2.52 megohms $\pm 1\%$, 1/2 W NN*	33-2.52M	1			
R323	Resistor: fixed, composition, 680,000 ohms $\pm 10\%$, 1 W B*	24-680K	2			
R324	Resistor: fixed, composition, 100,000 ohms $\pm 10\%$, 1 W B*	24-100K	1			
R325	Same as R305					
R326	Resistor: fixed, composition, 12,000 ohms $\pm 10\%$, 1 W B*	24-12K	1			
R327	Same as R263					
R328	Resistor: fixed, composition, 4700 ohms $\pm 10\%$, 1/2 W B*	23-4700	1			
R329	Same as R319					
R330	Same as R305					
R331	Same as R5					
R332	Resistor: variable, composition, linear taper, 250,000 ohms $\pm 30\%$, 1/4 W BO*	210-194	1			
R333	Same as R311					
R334	Resistor: variable, composition, linear taper, 1 megohm $\pm 30\%$, 1/4 W BO*	210-139	1			
R335	Resistor: fixed, deposited carbon, 20 megohms $\pm 10\%$, 1 W AV*	26-84	1			

* See "List of Manufacturers Code Letters For Replaceable Parts Table".

Total quantity used in the instrument.

TABLE OF REPLACEABLE PARTS

CIRCUIT REF.	DESCRIPTION, MFR. * & MFR. DESIGNATION	Ⓢ STOCK NO.	#			
R336	Resistor: variable, composition, linear taper, 5 megohms $\pm 30\%$, 1/2 W I*	210-159	1			
R337	Same as R5					
R338	Resistor: fixed, composition, 27,000 ohms $\pm 10\%$, 1/2 W B*	23-27K	1			
R339	Same as R304					
R340	This circuit reference not assigned					
R341	Same as R307					
R342	This circuit reference not assigned					
R343	Resistor: variable, composition, 1 megohm $\pm 30\%$, 0.2 W BO*	210-118	1			
R344, 345	These circuit references not assigned					
R346	Resistor: fixed, deposited carbon, 29 megohms $\pm 10\%$, 1 W AV*	26-85	1			
R347	This circuit reference not assigned					
R348	Resistor: fixed, composition, 270,000 ohms $\pm 10\%$, 1 W B*	24-270K	1			
R349	Same as R46					
R350	Resistor: fixed, composition, 47,000 ohms $\pm 10\%$, 1/2 W B*	23-47K	2			
R351	Resistor: fixed, composition, 1000 ohms $\pm 10\%$, 1/2 W B*	23-1000	2			
R352	Resistor: fixed, composition, 2000 ohms $\pm 5\%$, 1/2 W B*	23-2000-5	1			
R353	Resistor: fixed, composition, 510 ohms $\pm 5\%$, 1 W B*	24-510-5	1			
R354	Resistor: fixed, composition, 2700 ohms $\pm 10\%$, 1/2 W B*	23-2700	1			
R355, 356	Resistor: fixed, composition, 68,000 ohms $\pm 10\%$, 1/2 W B*	23-68K	2			

* See "List of Manufacturers Code Letters For Replaceable Parts Table".

Total quantity used in the instrument.

TABLE OF REPLACEABLE PARTS

CIRCUIT REF.	DESCRIPTION, MFR. * & MFR. DESIGNATION	Ⓢ STOCK NO.	#			
R357	Resistor: variable, wirewound, 25 ohms $\pm 10\%$, 2 W, linear taper BO*	210-188	1			
R358	Same as R323					
R359	Resistor: fixed, deposited carbon, 750,000 ohms $\pm 1\%$, 1/2 W NN*	33-750K	1			
R360	Resistor: fixed, composition, 10 megohms $\pm 10\%$, 1/2 W B*	23-10M	1			
R361	Resistor: fixed, composition, 56,000 ohms $\pm 10\%$, 1 W B*	24-56K	1			
R362	Resistor: fixed, composition, 150,000 ohms $\pm 10\%$, 1 W B*	24-150K	1			
R363	This circuit reference not assigned					
R364	Resistor: fixed, composition, 82,000 ohms $\pm 10\%$, 1/2 W B*	23-82K	1			
R365	Resistor: variable, composition, linear taper, 50,000 ohms $\pm 20\%$, G*	210-18	1			
R366	Resistor: fixed, composition, 33,000 ohms $\pm 10\%$, 1/2 W B*	23-33K	1			
R367	This circuit reference not assigned					
R368	Resistor: fixed, composition, 1 megohm $\pm 10\%$, 1/2 W B*	23-1M	1			
R369	Same as R350					
R370	Same as R351					
R371	Resistor: fixed, composition, 2.2 megohms $\pm 10\%$, 1/2 W B*	23-2.2M	1			
S1	Switch, toggle: SPST Vertical AC-DC Switch D*	310-11	1			
S2	Vertical Sensitivity Switch Assembly HP*	130B-95A	1			
S3	Part of R18: not separately replaceable					

* See "List of Manufacturers Code Letters For Replaceable Parts Table".

Total quantity used in the instrument.

TABLE OF REPLACEABLE PARTS

CIRCUIT REF.	DESCRIPTION, MFR. * & MFR. DESIGNATION	hp STOCK NO.	#			
S4 thru S100	These circuit references not assigned					
S101	Switch, rotary: 5 section, 16 pos.	W* 310-236	1			
S102	Horizontal Sensitivity Switch Assembly	HP* 130B-95B	1			
S103	Part of R118: not separately replaceable					
S104 thru S200	These circuit references not assigned					
S201	Sync Switch Assembly	HP* 130B-19H	1			
S202	Trigger Level Switch Assembly	HP* 130B-19G	1			
S203	Part of R218: not separately replaceable					
S204	Sweep Time/CM Switch Assembly	HP* 130B-19J	1			
S205	Part of R262: not separately replaceable					
S206 thru S300	These circuit references not assigned					
S301	Part of R357: not separately replaceable					
T1	Transformer, power	HP* 910-162	1			
V1, 2	Tube, electron: 12AU7	ZZ* 212-12AU7	4			
V3	Tube, electron: 12AT7	ZZ* 212-12AT7	3			
V4	Tube, electron: 6DJ8	ZZ* 212-6DJ8	3			
V5 thru V100	These circuit references not assigned					
V101, 102	Same as V1					
V103	Same as V3					
V104	Same as V4					
XV104						

* See "List of Manufacturers Code Letters For Replaceable Parts Table".

Total quantity used in the instrument.

TABLE OF REPLACEABLE PARTS

CIRCUIT REF.	DESCRIPTION, MFR. * & MFR. DESIGNATION	Ⓟ STOCK NO.	#				
V105 thru V200	These circuit references not assigned						
V201	Same as V4						
V202	Same as V3						
V203	Tube, electron: 6U8	ZZ* 212-6U8	1				
V204	Tube, electron: 6C4	212-6C4	1				
V205	Tube, electron: 12AL5	212-12AL5	1				
V206	Tube, electron: 6AW8A	212-6AW8A	1				
V207	Tube, electron: 12AX7	ZZ* 212-12AX7	1				
V208 thru V300	These circuit references not assigned						
V301	Tube, electron: 12B4A	ZZ* 212-12B4A	3				
V302	Tube, electron: 6AU6	ZZ* 212-6AU6	1				
V303	Same as V301						
V304	Tube, electron: 6BH6	ZZ* 212-6BH6	2				
V305	Tube, electron: 6X4	ZZ* 212-6X4	1				
V306	Same as V301						
V307	Same as V304						
V308	Tube, electron: 5651	ZZ* 212-5651	1				
V309	Tube, electron, cathode-ray type (Final number in tube designation denotes phosphor type)	212-5AQP-	1				
V310, 311	Tube, electron: 5642	ZZ* 212-5642	2				
V312	Tube, electron: 12AU7	ZZ* 212-12AU7	1				
V313	Tube, electron: 6AQ5	ZZ* 212-5642	1				
V314	Tube, electron: 6DJ8	ZZ* 212-6DJ8	1				

* See "List of Manufacturers Code Letters For Replaceable Parts Table".
 # Total quantity used in the instrument.

TABLE OF REPLACEABLE PARTS

CIRCUIT REF.	DESCRIPTION, MFR. * & MFR. DESIGNATION	Ⓜ STOCK NO.	#			
	<u>MISCELLANEOUS</u>					
	CRT bezel	HP* 120A-20A	1			
	Filter, light: amber	HP* 120A-83A	1			
	Filter, light: blue	HP* 120A-83B	1			
	Filter, light: green	HP* 120A-83G	1			
	Fuseholder	T* 140-16	1			
	Graticule	HP* 120A-83C	1			
	Holder, rectifier	T* 140-91	2			
	Jewel	HP* 145-23A	1			
	Knob: FOCUS, INTENSITY, SCALE LIGHT	G-74D	3			
		HP*				
	Knob: VERT.POS., HORIZ. POS.	HP* G-74G	2			
	Knob: TRIGGER LEVEL	HP* G-74L	1			
	Knob: VERT. SENSITIVITY, HORIZ. SENSITIVITY, SYNC TIME, SWEEP TIME	G-74Q	4			
		HP*				
	Knob: TRIGGER SLOPE	HP* G-74AT	1			
	Knob: VERNIER, VERT. SENSITIVITY, HORIZ. SENSITIVITY, SYNC TIME, SWEEP TIME	G-74AU	4			
		HP*				
	Knob: VERT. and HORIZ. DC BAL	HP* G-74BJ	2			
	Lampholder Assembly	JJ* 145-27	1			
	Pilot Light Assembly	AD* 145-25	1			

* See "List of Manufacturers Code Letters For Replaceable Parts Table".

Total quantity used in the instrument.

LIST OF CODE LETTERS USED IN TABLE OF REPLACEABLE PARTS TO DESIGNATE THE MANUFACTURERS

<u>CODE LETTER</u>	<u>MANUFACTURER</u>	<u>ADDRESS</u>	<u>CODE LETTER</u>	<u>MANUFACTURER</u>	<u>ADDRESS</u>
A	Aerovox Corp.	New Bedford, Mass.	AK	Hammerlund Mfg. Co., Inc.	New York 1, N. Y.
B	Allen-Bradley Co.	Milwaukee 4, Wis.	AL	Industrial Condenser Corp.	Chicago 18, Ill.
C	Amperite Co.	New York, N. Y.	AM	Insuline Corp. of America	Manchester, N. H.
D	Arrow, Hart & Hegeman	Hartford, Conn.	AN	Jennings Radio Mfg. Corp.	San Jose, Calif.
E	Bussman Manufacturing Co.	St. Louis, Mo.	AO	E. F. Johnson Co.	Waseca, Minn.
F	Carborundum Co.	Niagara Falls, N. Y.	AP	Lenz Electric Mfg. Co.	Chicago 47, Ill.
G	Centralab	Milwaukee 1, Wis.	AQ	Micro-Switch	Freeport, Ill.
H	Cinch-Jones Mfg. Co.	Chicago 24, Ill.	AR	Mechanical Industries Prod. Co.	Akron 8, Ohio
HP	Hewlett-Packard Co.	Palo Alto, Calif.	AS	Model Eng. & Mfg., Inc.	Huntington, Ind.
I	ClaroStat Mfg. Co.	Dover, N. H.	AT	The Muter Co.	Chicago 5, Ill.
J	Cornell Dubilier Elec. Co.	South Plainfield, N. J.	AU	Ohmite Mfg. Co.	Skokie, Ill.
K	Hi-Q Division of Aerovox	Olean, N. Y.	AV	Resistance Products Co.	Harrisburg, Pa.
L	Erie Resistor Corp.	Erie 6, Pa.	AW	Radio Condenser Co.	Camden 3, N. J.
M	Fed. Telephone & Radio Corp.	Clifton, N. J.	AX	Shallcross Manufacturing Co.	Collingdale, Pa.
N	General Electric Co.	Schenectady 5, N. Y.	AY	Solar Manufacturing Co.	Los Angeles 58, Calif.
O	General Electric Supply Corp.	San Francisco, Calif.	AZ	Sealectro Corp.	New Rochelle, N. Y.
P	Girard-Hopkins	Oakland, Calif.	BA	Spencer Thermostat	Attleboro, Mass.
Q	Industrial Products Co.	Danbury, Conn.	BC	Stevens Manufacturing Co.	Mansfield, Ohio
R	International Resistance Co.	Philadelphia 8, Pa.	BD	Torrington Manufacturing Co.	Van Nuys, Calif.
S	Lectrohm Inc.	Chicago 20, Ill.	BE	Vector Electronic Co.	Los Angeles 65, Calif.
T	Littlefuse Inc.	Des Plaines, Ill.	BF	Weston Electrical Inst. Corp.	Newark 5, N. J.
U	Maguire Industries Inc.	Greenwich, Conn.	BG	Advance Electric & Relay Co.	Burbank, Calif.
V	Micamold Radio Corp.	Brooklyn 37, N. Y.	BH	E. I. DuPont	San Francisco, Calif.
W	Oak Manufacturing Co.	Chicago 10, Ill.	BI	Electronics Tube Corp.	Philadelphia 18, Pa.
X	P. R. Mallory Co., Inc.	Indianapolis, Ind.	BJ	Aircraft Radio Corp.	Boonton, N. J.
Y	Radio Corp. of America	Harrison, N. J.	BK	Allied Control Co., Inc.	New York 21, N. Y.
Z	Sangamo Electric Co.	Marion, Ill.	BL	Augat Brothers, Inc.	Attleboro, Mass.
AA	Sarkes Tarzian	Bloomington, Ind.	BM	Carter Radio Division	Chicago, Ill.
BB	Signal Indicator Co.	Brooklyn 37, N. Y.	BN	CBS Hytron Radio & Electric	Danvers, Mass.
CC	Sprague Electric Co.	North Adams, Mass.	BO	Chicago Telephone Supply	Elkhart, Ind.
DD	Stackpole Carbon Co.	St. Marys, Pa.	BP	Henry L. Crowley Co., Inc.	West Orange, N. J.
EE	Sylvania Electric Products Co.	Warren, Pa.	BQ	Curtiss-Wright Corp.	Carlstadt, N. J.
FF	Western Electric Co.	New York 5, N. Y.	BR	Allen B. DuMont Labs	Clifton, N. J.
GG	Wilkor Products, Inc.	Cleveland, Ohio	BS	Excel Transformer Co.	Oakland, Calif.
HH	Amphenol	Chicago 50, Ill.	BT	General Radio Co.	Cambridge 39, Mass.
II	Dial Light Co. of America	Brooklyn 37, N. Y.	BU	Hughes Aircraft Co.	Culver City, Calif.
JJ	Leecraft Manufacturing Co.	New York, N. Y.	BV	International Rectifier Corp.	El Segundo, Calif.
KK	Switchcraft, Inc.	Chicago 22, Ill.	BW	James Knights Co.	Sandwich, Ill.
LL	Gremar Manufacturing Co.	Wakefield, Mass.	BX	Mueller Electric Co.	Cleveland, Ohio
MM	Carad Corp.	Redwood City, Calif.	BY	Precision Thermometer & Inst. Co.	Philadelphia 30, Pa.
NN	Electra Manufacturing Co.	Kansas City, Mo.	BZ	Radio Essentials Inc.	Mt. Vernon, N. Y.
OO	Acro Manufacturing Co.	Columbus 16, Ohio	CA	Raytheon Manufacturing Co.	Newton, Mass.
PP	Alliance Manufacturing Co.	Alliance, Ohio	CB	Tung-Sol Lamp Works, Inc.	Newark 4, N. J.
QQ	Arco Electronics, Inc.	New York 13, N. Y.	CD	Varian Associates	Palo Alto, Calif.
RR	Astron Corp.	East Newark, N. J.	CE	Victory Engineering Corp.	Union, N. J.
SS	Axel Brothers Inc.	Long Island City, N. Y.	CF	Weckesser Co.	Chicago 30, Ill.
TT	Belden Manufacturing Co.	Chicago 44, Ill.	CG	Wilco Corporation	Indianapolis, Ind.
UU	Bird Electronics Corp.	Cleveland 14, Ohio	CH	Winchester Electronics, Inc.	Santa Monica, Calif.
VV	Barber Colman Co.	Rockford, Ill.	CI	Malco Tool & Die	Los Angeles 42, Calif.
WW	Bud Radio Inc.	Cleveland 3, Ohio	CJ	Oxford Electric Corp.	Chicago 15, Ill.
XX	Allen D. Cardwell Mfg. Co.	Plainville, Conn.	CK	Camloc-Fastener Corp.	Paramus, N. J.
YY	Cinema Engineering Co.	Burbank, Calif.	CL	George K. Garrett	Philadelphia 34, Pa.
ZZ	Any brand tube meeting RETMA standards.		CM	Union Switch & Signal	Swissvale, Pa.
AB	Corning Glass Works	Corning, N. Y.	CN	Radio Receptor	New York 11, N. Y.
AC	Dale Products, Inc.	Columbus, Neb.	CO	Automatic & Precision Mfg. Co.	Yonkers, N. Y.
AD	The Drake Mfg. Co.	Chicago 22, Ill.	CP	Bassick Co.	Bridgeport 2, Conn.
AE	Elco Corp.	Philadelphia 24, Pa.	CQ	Birnbach Radio Co.	New York 13, N. Y.
AF	Hugh H. Eby Co.	Philadelphia 44, Pa.	CR	Fischer Specialties	Cincinnati 6, Ohio
AG	Thomas A. Edison, Inc.	West Orange, N. J.	CS	Telefunken (c/o MYM, Inc.)	New York, N. Y.
AH	Fansteel Metallurgical Corp.	North Chicago, Ill.	CT	Potter-Brumfield Co.	Princeton, Ind.
AI	General Ceramics & Steatite Corp.	Keasbey, N. J.	CU	Cannon Electric Co.	Los Angeles, Calif.
AJ	The Gudeman Co.	Sunnyvale, Calif.	CV	Dynac, Inc.	Palo Alto, Calif.
			CW	Good-All Electric Mfg. Co.	Ogallala, Nebr.

CLAIM FOR DAMAGE IN SHIPMENT

The instrument should be tested as soon as it is received. If it fails to operate properly, or is damaged in any way, a claim should be filed with the carrier. A full report of the damage should be obtained by the claim agent, and this report should be forwarded to us. We will then advise you of the disposition to be made of the equipment and arrange for repair or replacement. Include model number and serial number when referring to this instrument for any reason.

WARRANTY

Hewlett-Packard Company warrants each instrument manufactured by them to be free from defects in material and workmanship. Our liability under this warranty is limited to servicing or adjusting any instrument returned to the factory for that purpose and to replace any defective parts thereof. Klystron tubes as well as other electron tubes, fuses and batteries are specifically excluded from any liability. This warranty is effective for one year after delivery to the original purchaser when the instrument is returned, transportation charges prepaid by the original purchaser, and when upon our examination it is disclosed to our satisfaction to be defective. If the fault has been caused by misuse or abnormal conditions of operation, repairs will be billed at cost. In this case, an estimate will be submitted before the work is started.

If any fault develops, the following steps should be taken:

1. Notify us, giving full details of the difficulty, and include the model number and serial number. On receipt of this information, we will give you service data or shipping instructions.
2. On receipt of shipping instructions, forward the instrument prepaid, to the factory or to the authorized repair station indicated on the instructions. If requested, an estimate of the charges will be made before the work begins provided the instrument is not covered by the warranty.

SHIPPING

All shipments of Hewlett-Packard instruments should be made via Truck or Railway Express. The instruments should be packed in a strong exterior container and surrounded by two or three inches of excelsior or similar shock-absorbing material.

DO NOT HESITATE TO CALL ON US

HEWLETT-PACKARD COMPANY

Laboratory Instruments for Speed and Accuracy

275 PAGE MILL ROAD

CABLE



PALO ALTO, CALIF. U.S.A.

"HEWPACK"

